

Think Automation and beyond...



# RV8H *New* Interface Relays



**Slim, space-saving interface relays.  
Smallest in its class!**

Slim Width  
**6**mm

IDEC CORPORATION

# Ultra-slim interface relays

## Suitable for high density mounting

- Screw and spring clamp terminals
- Release lever for easy locking and removal of relay



- Green LED indicator
- 6A contact capacity in the slim housing
- Gold-plated contacts for high contact reliability
- Minimum applicable load: 6V DC, 10mA
- 12 coil voltage types to meet various needs

Marking plate  
can be installed  
on the release  
lever.

Only **70** mm  
from the DIN rail  
Shortest in its class

Slim Width  
**6** mm

# RV8H

# RV8H Interface Relays

Space-saving 6mm width suitable for high density mounting.

- Screw and spring clamp terminals available
- Release lever for easy locking and removal of relay
- Green LED indicator
- 6A contact capacity in a slim housing
- Gold-plated contacts for high contact reliability
- Wide input voltage range: 6 to 240V
- Marking plate can be installed on the release lever



Applicable Standards	Mark	Certification Organization /File No.
UL508 CSA C22.2 No. 14		RV8H Screw terminal UL/c-UL listed, File No. E55996
UL60947-4-1A CSA C22.2 No. 60947-4-1		RV8H Spring clamp terminal UL/c-UL listed, File No. E55996
UL508 CSA C22.2 No. 14		RV1H UL/c-UL recognized, File No. E59804
EN61810-1		VDE No. 40030148 (RV1H relay only)
		EU Low Voltage Directive
EN60999-1 EN61000-6-2 EN61000-6-4		EU Low Voltage Directive EMC Directive

## Interface Relays

Package Quantity: 1

Contact Arrangement	Coil Voltage	Part No.			
		Screw Terminal	Spring Clamp Terminal		
SPDT	6V DC		<b>RV8H-L-D6</b>		<b>RV8H-S-D6</b>
	9V DC		<b>RV8H-L-D9</b>		<b>RV8H-S-D9</b>
	12V DC		<b>RV8H-L-D12</b>		<b>RV8H-S-D12</b>
	18V DC		<b>RV8H-L-D18</b>		<b>RV8H-S-D18</b>
	24V DC		<b>RV8H-L-D24</b>		<b>RV8H-S-D24</b>
	12V AC/DC		<b>RV8H-L-AD12</b>		<b>RV8H-S-AD12</b>
	18V AC/DC		<b>RV8H-L-AD18</b>		<b>RV8H-S-AD18</b>
	24V AC/DC		<b>RV8H-L-AD24</b>		<b>RV8H-S-AD24</b>
	48V AC/DC		<b>RV8H-L-AD48</b>		<b>RV8H-S-AD48</b>
	60V AC/DC		<b>RV8H-L-AD60</b>		<b>RV8H-S-AD60</b>
	110-125V AC/DC		<b>RV8H-L-AD110</b>		<b>RV8H-S-AD110</b>
	220-240V AC/DC		<b>RV8H-L-AD220</b>		<b>RV8H-S-AD220</b>

## Accessories

### Relay / Socket

Package Quantity: 1

Screw Terminal		
Interface Relay Complete Part No.	Applicable Socket Part No.	Applicable Relay Part No.
<b>RV8H-L-D6</b>		<b>RV1H-G-D5</b>
<b>RV8H-L-D9</b>		<b>RV1H-G-D9</b>
<b>RV8H-L-D12</b>		<b>RV1H-G-D12</b>
<b>RV8H-L-D18</b>		<b>RV1H-G-D18</b>
<b>RV8H-L-D24</b>	<b>RV1H-G-D24</b>	
<b>RV8H-L-AD12</b>		<b>RV1H-G-D12</b>
<b>RV8H-L-AD18</b>		<b>RV1H-G-D18</b>
<b>RV8H-L-AD24</b>		<b>RV1H-G-D24</b>
<b>RV8H-L-AD48</b>		<b>RV1H-G-D48</b>
<b>RV8H-L-AD60</b>		<b>RV1H-G-D60</b>
<b>RV8H-L-AD110</b>		<b>RV1H-G-D60</b>
<b>RV8H-L-AD220</b>		<b>RV1H-G-D60</b>
		<b>RV1H-G-D60</b>



Spring Clamp Terminal		
Interface Relay Complete Part No.	Applicable Socket Part No.	Applicable Relay Part No.
<b>RV8H-S-D6</b>		<b>RV1H-G-D5</b>
<b>RV8H-S-D9</b>		<b>RV1H-G-D9</b>
<b>RV8H-S-D12</b>		<b>RV1H-G-D12</b>
<b>RV8H-S-D18</b>		<b>RV1H-G-D18</b>
<b>RV8H-S-D24</b>	<b>RV1H-G-D24</b>	
<b>RV8H-S-AD12</b>		<b>RV1H-G-D12</b>
<b>RV8H-S-AD18</b>		<b>RV1H-G-D18</b>
<b>RV8H-S-AD24</b>		<b>RV1H-G-D24</b>
<b>RV8H-S-AD48</b>		<b>RV1H-G-D48</b>
<b>RV8H-S-AD60</b>		<b>RV1H-G-D60</b>
<b>RV8H-S-AD110</b>		<b>RV1H-G-D60</b>
<b>RV8H-S-AD220</b>		<b>RV1H-G-D60</b>
		<b>RV1H-G-D60</b>

# RV8H Interface Relays

## Marking Plate

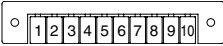
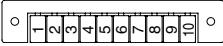
Package Quantity: 1

Shape	Marking										Part No.	
No marking  Material: PBT (white)	Blank										SV9Z-PW10	
Vertical laser marking  Material: PBT (white)	1	2	3	4	5	6	7	8	9	10	SV9Z-PW10-V1-10	
	11	12	13	14	15	16	17	18	19	20	SV9Z-PW10-V11-20	
	21	22	23	24	25	26	27	28	29	30	SV9Z-PW10-V21-30	
	31	32	33	34	35	36	37	38	39	40	SV9Z-PW10-V31-40	
	41	42	43	44	45	46	47	48	49	50	SV9Z-PW10-V41-50	
	51	52	53	54	55	56	57	58	59	60	SV9Z-PW10-V51-60	
	61	62	63	64	65	66	67	68	69	70	SV9Z-PW10-V61-70	
	71	72	73	74	75	76	77	78	79	80	SV9Z-PW10-V71-80	
	81	82	83	84	85	86	87	88	89	90	SV9Z-PW10-V81-90	
	91	92	93	94	95	96	97	98	99	100	SV9Z-PW10-V91-100	
	A	B	C	D	E	F	G	H	I	J	SV9Z-PW10-VA-J	
	K	L	M	N	O	P	Q	R	S	T	SV9Z-PW10-VK-T	
	U	V	W	X	Y	Z					SV9Z-PW10-VU-Z	
	⏏	⏏	⏏	⏏	⏏	⏏	⏏	⏏	⏏	⏏	SV9Z-PW10-VGROUND	
	?	?	?	?	?	?	?	?	?	?	SV9Z-PW10-VAC	
	Horizontal laser marking  Material: PBT (white)	1	11	2	12	3	13	4	14	5	15	SV9Z-PW10-H1-10
		6	16	7	17	8	18	9	19	10	20	SV9Z-PW10-H11-20
		21	21	22	22	23	23	24	24	25	25	SV9Z-PW10-H21-30
		31	31	32	32	33	33	34	34	35	35	SV9Z-PW10-H31-40
		41	41	42	42	43	43	44	44	45	45	SV9Z-PW10-H41-50
51		51	52	52	53	53	54	54	55	55	SV9Z-PW10-H51-60	
61		61	62	62	63	63	64	64	65	65	SV9Z-PW10-H61-70	
71		71	72	72	73	73	74	74	75	75	SV9Z-PW10-H71-80	
81		81	82	82	83	83	84	84	85	85	SV9Z-PW10-H81-90	
91		91	92	92	93	93	94	94	95	95	SV9Z-PW10-H91-100	
A		A	B	B	C	C	D	D	E	E	SV9Z-PW10-HA-J	
K		K	L	L	M	M	N	N	O	O	SV9Z-PW10-HK-T	
U		U	V	V	W	W	X	X	Y	Y	SV9Z-PW10-HU-Z	
⏏		⏏	⏏	⏏	⏏	⏏	⏏	⏏	⏏	⏏	SV9Z-PW10-HGROUND	
?		?	?	?	?	?	?	?	?	?	SV9Z-PW10-HAC	

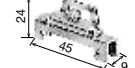
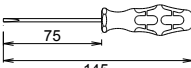
Shape	Material	Part No.	Package Quantity	Note
Jumper Rated current: 6A (Note) 	Brass (nickel-plated) with polyamide sheath Approx. 6g	SV9Z-J20*	10	Specify a color code in place of * in the Part No. B: black W: gray S: blue Can be cut to required length. No. of points: 20
DIN Rail Spacer	Polyamide (gray)	SV9Z-SA2W	1	Used for adjusting spacing between sockets and to prevent the ends of jumpers from exposing.
DIN Rail	Aluminum, approx. 200g	BAA1000PN10	10	1m long 35mm wide
	Steel, approx. 320g	BAP1000PN10		
End Clip	Zinc-plated steel Approx. 15g	BNL5PN10	10	
		BNL6PN10		
Applicable Screwdriver	Weight: 20g	BC1S-SD0	1	

Note: Ensure that the total current to the jumper does not exceed the rated current.

# RV8H Interface Relays

## Contact Ratings

Allowable Contact Power		Rated Load			Allowable Switching Current	Allowable Switching Voltage	Minimum Applicable Load
Resistive Load	Inductive Load	Voltage	Resistive Load	Inductive Load			
1,500VA AC 180W DC	B300: AC 360 VA R300: DC 28 VA (pilot duty)	250V AC 30V DC	6A 6A	B300: 240V AC 1.5A R300: 250V DC 0.11A (pilot duty)	6A	400V AC 125V DC	6V DC, 10 mA (reference value)

## Coil Ratings

Rated Voltage (V)	Coil Voltage Code	Rated Current (mA) ±15% (at 23°C) (Note)	Coil Resistance (Ω) ±15% (at 23°C) (Note)	Impedance (Ω) ±15% (at 23°C)	Operating Characteristics (against rated values at 23°C)			Power Consumption	
					Maximum Continuous Applied Voltage (Note)	Minimum Pickup Voltage	Dropout Voltage		
DC	6V DC	D6	35	170	110%	90% maximum	7% minimum	0.21	
	9V DC	D9	18.6	485				0.2	
	12V DC	D12	14.6	820				0.25	
	18V DC	D18	11.6	1,550				0.2	
	24V DC	D24	10.6	2,270				0.25	
AC/DC	12V AC/DC	AD12	15.5	800				755	0.33
	18V AC/DC	AD18	13.3	1,345				1,365	0.2
	24V AC/DC	AD24	13.7	1,790				1,730	0.25
	48V AC/DC	AD48	4.0	12,230				11,880	0.2
	60V AC/DC	AD60	3.4	17,910				17,600	0.5
	110-125V AC/DC	AD110	3.4-3.9	32,450-32,900	31,790-31,890	0.85			
	220-240V AC/DC	AD220	3.3-3.6	65,940-68,570	65,670-66,070	0.85			

Note: D12 and below: ±10%

## UL and c-UL Ratings

Voltage	Resistive	Inductive
250V AC	6A	B300/R300
30V DC	6A	(pilot duty)

## VDE Ratings (RV1H relay only)

Voltage	Resistive
250V AC	6A
30V DC	6A

## Specifications

Part No.	RV8H-L (Screw Terminal)	RV8H-S (Spring Clamp Terminal)
Number of Poles	1-pole	
Contact Configuration	SPDT	
Contact Material	Silver alloy (gold-plated)	
Degree of Protection	Relay: IP67, Socket: IP20 (IEC 60529)	
Contact Resistance (initial value)	100mΩ maximum	
Operate Time	15ms maximum	
Release Time	20ms maximum	
Insulation Resistance	1,000MΩ minimum (500V DC megger)	
Dielectric Strength	Between contact and coil	4,000V AC, 1 minute
	Between contacts of the same pole	1,000V AC, 1 minute
Vibration Resistance	Operation extremes	10 to 55 Hz, amplitude 0.5mm (NO contact), 0.2mm (NC contact)
	Damage Limits	10 to 55 Hz, amplitude 0.5mm (NO contact), 0.2mm (NC contact)
Shock Resistance	Operation extremes	49 m/s <sup>2</sup> (NO contact), 29.4 m/s <sup>2</sup> (NC contact)
	Damage Limits	980 m/s <sup>2</sup>
Electrical Life (rated load)	30,000 operations minimum (NO contact), 10,000 operations minimum (NC contact) (250V AC/30V DC, 6A resistive load, operation frequency 1,800 operations per hour)	
Mechanical Life (no load)	10 million operations minimum (operation frequency 18,000 operations/hour)	
Operating Temperature	RV8H-*-D6, D9, D12, D18, D24, AD12, AD18, AD24, AD48, AD60: -40 to +70°C (no freezing) RV8H-*-AD110, AD220: -40 to +55°C (no freezing)	
Operating Humidity	5 to 85% RH (no condensation)	
Storage Temperature	-40 to +85°C (no freezing)	
Storage Humidity	5 to 85% RH (no condensation)	
Weight (approx.)	30g	26g

# RV8H Interface Relays

## Dimensions

### Screw Terminal RV8H-L

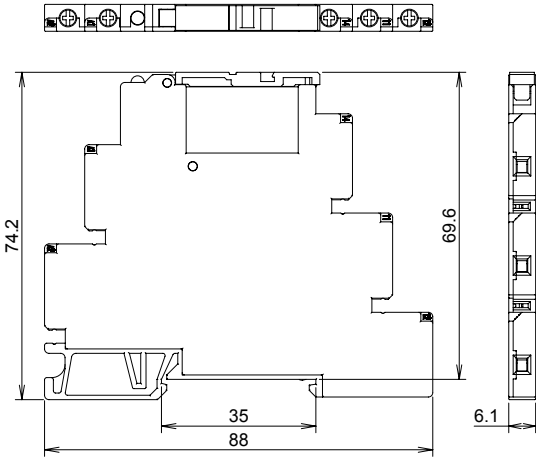

### Spring Clamp Terminal RV8H-S

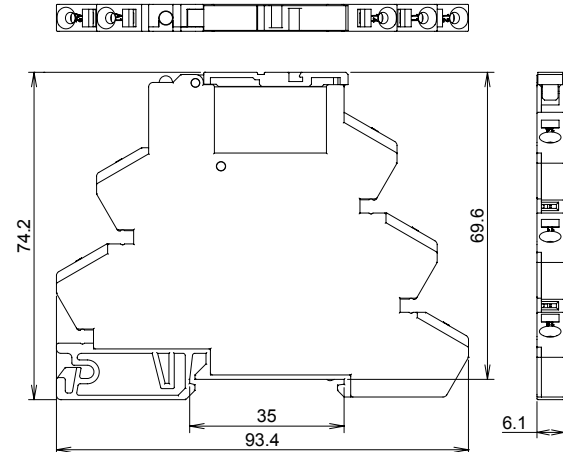

### Jumper SV9Z-J20\*PN10

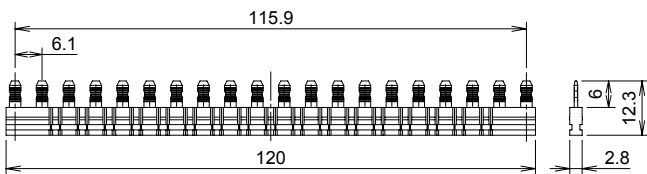

### DIN Rail Spacer SV9Z-SA2W

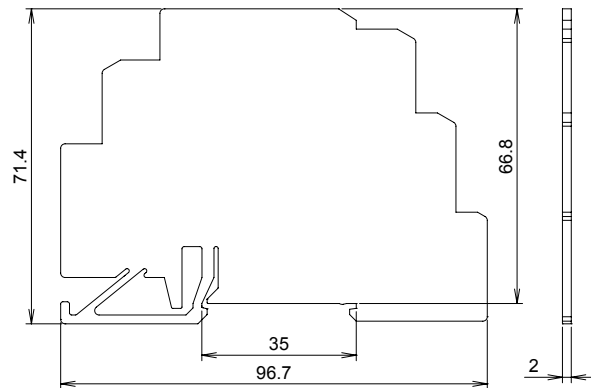

### Marking Plate SV9Z-PW10

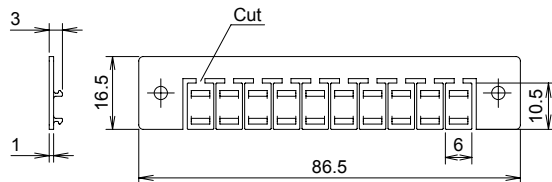

All dimensions in mm.

### Installing a marking plate

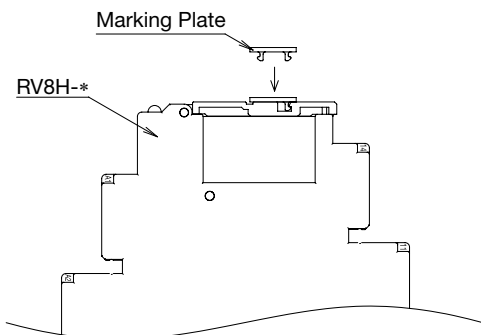

### RV1H Internal Connection (bottom view)

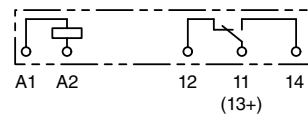

### RV8H Internal Connection

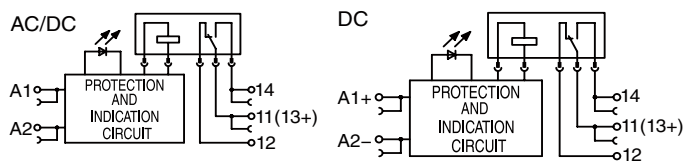

## Terminal Arrangement

### AC/DC

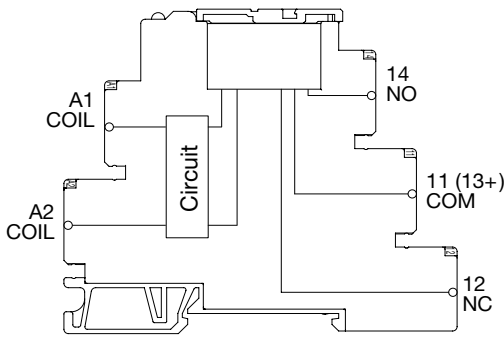

### DC

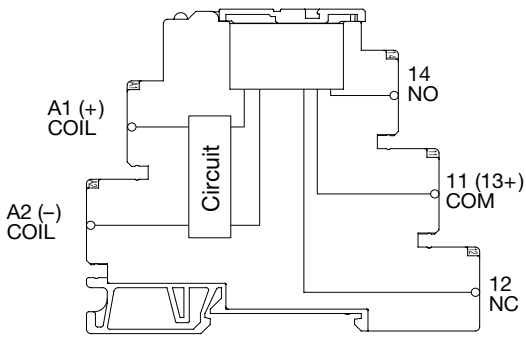

## Electrical Life Curve

### Resistive Load

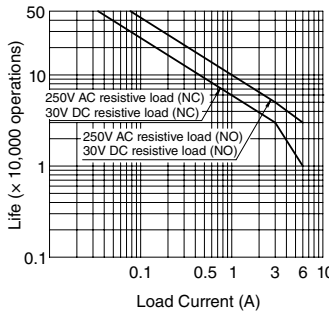

### Inductive Load

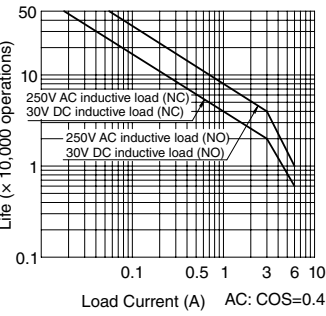

## Maximum Switching Current

### AC

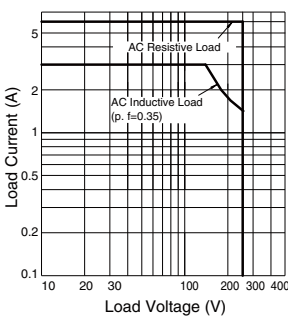

### DC

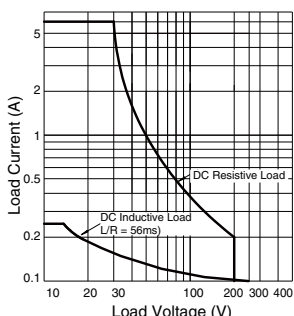

## ⚠ Safety Precautions

- Turn off power before starting installation, removal, wiring, maintenance, and inspection. Failure to turn power off may cause electrical shocks or fire hazard.
- Use proper wires to meet the voltage and current requirements.
- Make sure that relay and output equipment are connected completely. Incomplete connection may cause overheat, resulting in fire hazard.
- To ensure safety, make sure that all descriptions in the operation instructions are followed strictly.
- Prevent metal fragments and pieces of wire from dropping inside the sockets. Ingress of such fragments and chips may cause fire, failure, or malfunction.
- Apply voltage that is applicable to the relay and socket. Otherwise fire, failure, or malfunction will be caused.

## Operating Instructions

- Use a 15A non-time delay fuse for protection against short-circuit.
- When lightning surge may enter the input circuit of types AD12, AD18, and AD24, and when lightning surge and noise may enter the input circuit of types AD48 and AD60 of the following products, use a proper varistor. Otherwise, failure may be caused.

Relay	Recommended Varistor
RV8H-L-AD12	Panasonic ERZV07D390
RV8H-L-AD18	
RV8H-L-AD24	
RV8H-L-AD48	Panasonic ERZV14D121
RV8H-L-AD60	
RV8H-S-AD12	
RV8H-S-AD18	Panasonic ERZV07D390
RV8H-S-AD24	
RV8H-S-AD48	
RV8H-S-AD60	Panasonic ERZV14D121

- Observe the maximum ambient temperature shown below. Otherwise, fire, failure, or malfunction will be caused.  
 55°C maximum: RV8H-L-AD110/AD220  
 RV8H-S-AD110/AD220  
 70°C maximum: All other part nos.

## Wiring Instructions

### RV8H-L

- Use the following applicable wires for wiring.  
 2.5m<sup>2</sup> max. or AWG14 max., CU (copper), Stranded or Solid wire : 1  
 1.5m<sup>2</sup> max. or AWG16 max., CU (copper), Stranded wire : 2 max.  
 ø1.3mm max. or AWG16 max., CU(copper) solid wire : 2 max.

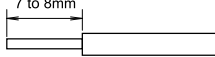

- Strip the wire insulation 7 to 8 mm from the end. Stripping the wire insulation too short may cause the wire to come off. Stripping the wire insulation too long may cause short-circuit with the adjacent socket. Make sure to twist the stranded wire to prevent loosening.
- For wiring, use the following applicable screwdriver.  
 Phillips screwdriver ø3.5mm max.  
 Flat screwdriver

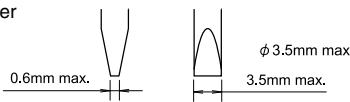

Recommended tightening torque: 0.3 N·m to 0.4 N·m  
 (UL certified: 0.35 N·m)

# RV8H Interface Relays

## RV8H-S

- Use the following applicable wires for wiring.  
0.5mm<sup>2</sup> to 2.5mm<sup>2</sup> or AWG20 to AWG14, CU (copper),  
Stranded or Solid wire: 1

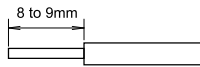

- Strip the wire insulation 8 to 9 mm from the end. Stripping the wire insulation too short may cause the wire to come off. Stripping the wire insulation too long may cause short-circuit with the adjacent socket. Make sure to twist the stranded wire to prevent loosening.
- For wiring, use the optional screwdriver (BC1S-SD0) or the following applicable screwdriver.

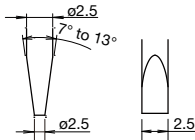

- Wire insertion positions, screwdriver insertion positions, and the directions of screwdriver tip are shown below.

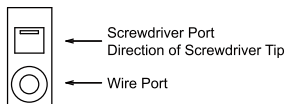

- In applications using ferrules for stranded wires, choose the ferrule listed in the table.

Applicable Wire		Part No.	Manufacturer
mm <sup>2</sup>	AWG		
0.5	20	AI0.5-8WH	Phoenix Contact
0.75	18	AI0.75-8GY	
1	18	AI1-8RD	
0.5	22	TE0.5-8	Nichifu
0.75	20	TE0.75-8	
1	18	TE1.0-8	

## Wiring Instructions

- Insert the optional screwdriver (BC1S-SD0) or an applicable screwdriver into the square-shaped port as shown, until the screwdriver tip touches the bottom of the spring.

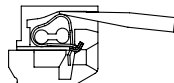

- Push in the screwdriver until it touches the bottom of the port. The wire port is now open, and the screwdriver is held in place. The screwdriver will not come off even if you release your hand.

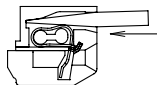

- While the screwdriver is retained in the port, insert the wire or ferrule into the round-shaped wire port. Each wire port can accommodate one wire or ferrule. When connecting two wires to one terminal, use the adjoining port of the same terminal.

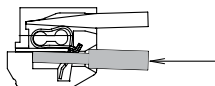

- Pull out the screwdriver. The connection is now complete.

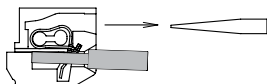

Note: When using wire with insulation diameter of  $\phi 2.0\text{mm}$  or less, do not insert the wire too deep where the insulation inserts into the spring clamp opening. Otherwise conductive failure will be caused. Make sure that the wire insulation is stripped 8 to 9 mm and the wire is inserted to the bottom.

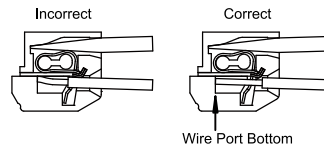

## Removing the Relay

- Open the release lever in the direction of the arrow, and remove the relay.

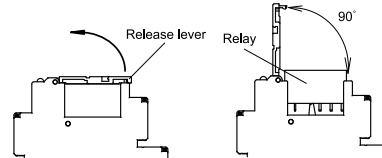

Note 1: The relay may pop out when opening the release lever, resulting in possible damage or loss of the relay. To prevent this, rightly press down the relay using a finger when opening the release lever.

Note 2: Do not open the release lever more than 90°, otherwise the socket will be damaged.

## Installing the Relay

- Open the release lever, and insert the relay into the socket until the bottom of relay touches the projection of the socket. Close the release lever until it is latched.

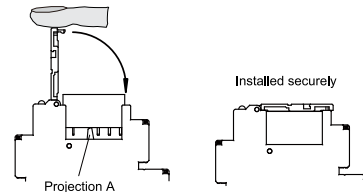

Note: When installing the relay, do not press in using a relay. Make sure to use the release lever, otherwise the projection A will be damaged.

## Installing the Socket

- Put the groove on the socket (part B) on the DIN rail, and press the socket towards the DIN rail as shown in the figure.

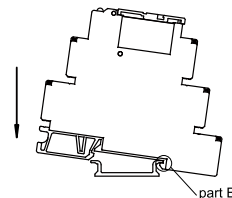

## Removing the Socket

- Insert a small flat screwdriver into the slot (part C) of the socket, and pull out the socket as shown in the figure.

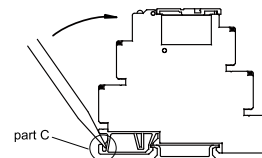

Note: When using the RV8H in cold temperature (0°C or below), install or remove the socket on the mounting rail carefully so that the socket will not be damaged.

Specifications and other descriptions in this catalog are subject to change without notice.



## IDEC CORPORATION

6-64, Nishi-Miyahara 2-Chome, Yodogawa-ku, Osaka 532-0004, Japan  
Tel: +81-6-6398-2571, Fax: +81-6-6392-9731  
E-mail: marketing@idec.co.jp

**IDEC CORPORATION (USA)**  
Tel: +1-408-747-0550 / (800) 262-IDEC (4332)  
E-mail: opencontact@idec.com  
**IDEC CANADA LIMITED**  
Tel: +1-905-890-8561, Toll Free: (800) 262-IDEC (4332)  
E-mail: sales@ca.idec.com  
**IDEC AUSTRALIA PTY. LTD.**  
Tel: +61-3-8523-5900, Toll Free: 1800-68-4332  
E-mail: sales@au.idec.com

**IDEC ELECTRONICS LIMITED**  
Tel: +44-1256-321000 E-mail: sales@uk.idec.com  
**IDEC ELEKTROTECHNIK GmbH**  
Tel: +49-40-25 30 54 - 0 E-mail: service@idec.de  
**IDEC (SHANGHAI) CORPORATION**  
Tel: +86-21-6135-1515 E-mail: idec@cn.idec.com  
**IDEC (BEIJING) CORPORATION**  
Tel: +86-10-6581-6131

**IDEC (SHENZHEN) CORPORATION**  
Tel: +86-755-8356-2977  
**IDEC IZUMI (H.K.) CO., LTD.**  
Tel: +852-2803-8989 E-mail: info@hk.idec.com  
**IDEC TAIWAN CORPORATION**  
Tel: +886-2-2698-3929 E-mail: service@tw.idec.com  
**IDEC IZUMI ASIA PTE. LTD.**  
Tel: +65-6746-1155 E-mail: info@sg.idec.com

www.idec.com