

PC Board Terminal Blocks

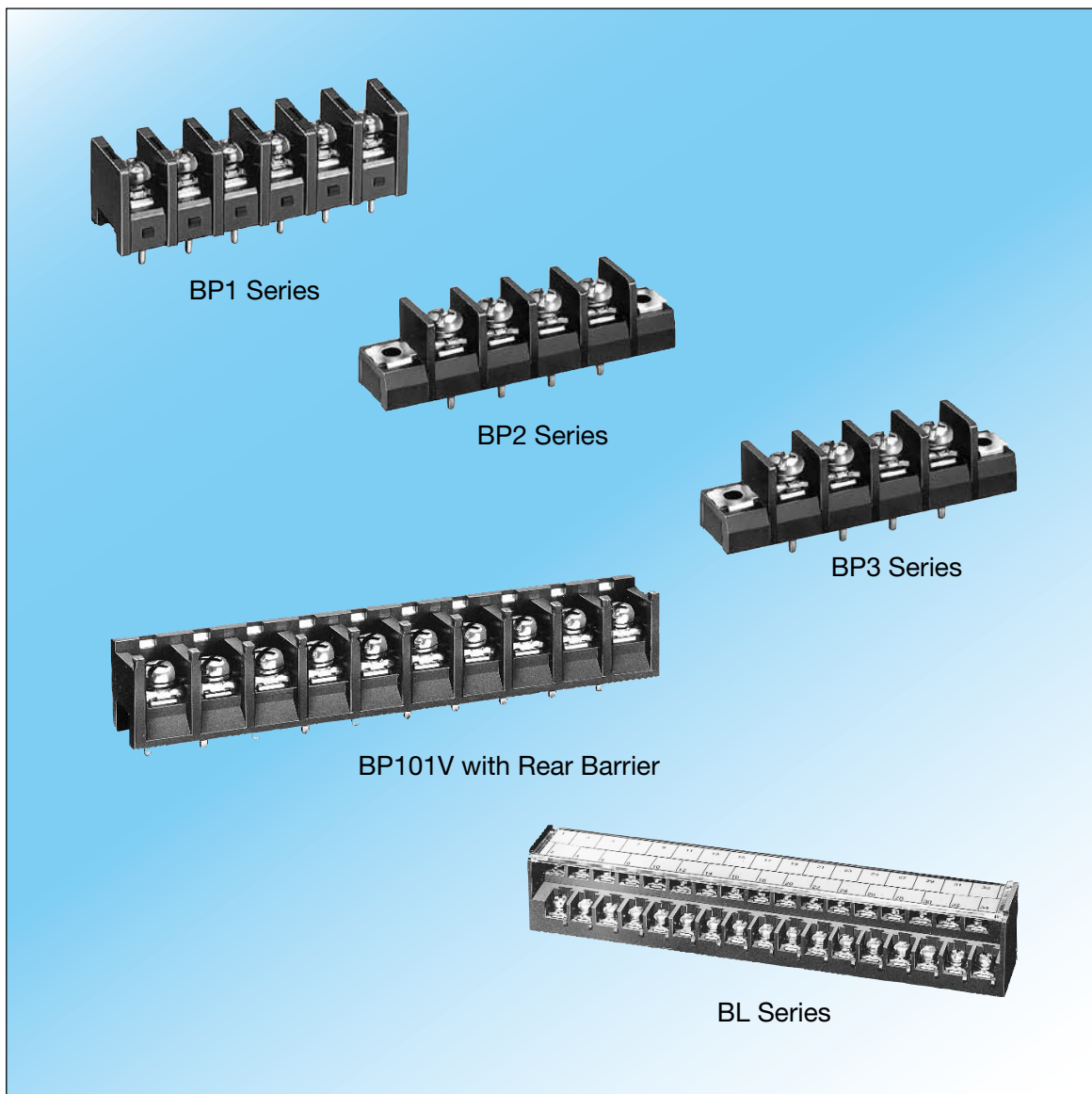

BP1 Series

BP2 Series



BP3 Series

BP101V with Rear Barrier

BL Series

PC Board Terminal Blocks (Selection Guide)

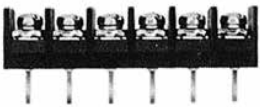
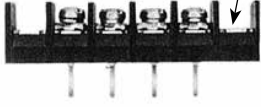
BP series PC Board Terminal Blocks

Terminal Style		Terminal Centers (mm)	01	11	21
			Basic Model	Straight Model	Right-angle Model
BP1	 (see pages 5 to 8)	7.62	BP101S	BP111S	BP121S
		9.5	BP101	BP111	BP121
		10	BP101	BP111	BP121
		11	BP101L	BP111L	BP121L
BP2	 (see pages 9 to 13)	7.62	BP201S	BP211S	BP221S
		9.5	BP201M	BP211M	BP221M
		10	BP201	BP211	BP221
		11	BP201L	BP211L	BP221L
BP3	 (see pages 14 to 18)	7.62	BP301S	BP311S	BP321S
		9.5	BP301M	BP311M	BP321M
		10	BP301	BP311	BP321
		11	BP301L	BP311L	BP321L

BP series Rear Barrier Terminal Blocks

Shape	Terminal Centers (mm)	Part No.	No. of Poles (P)
With Rear Barrier  (see page 19)	10	BP101V	2 to 15

BL series Double-deck Terminal Blocks

Shape	Terminal Centers (mm)	Part No.	No. of Poles (P)
Double-deck Model  (see page 26)	7.62	BL2B	10, 16, 20, 30, 34
	8.5	BL2C	
	10	BL2E	

Ordering Information

Ordering Part No.

BP1 01 S - 20 PN10

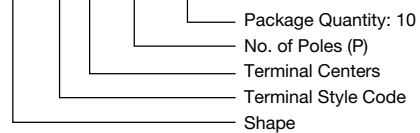

Ordering Part No.

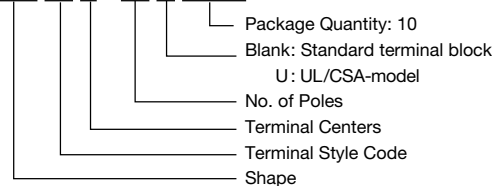

(UL-recognized/CSA-certified models)

BP1 01 S - 20 U PN10

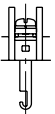

* When ordering, specify the Ordering Part No.

PC Board Terminal Blocks (Selection Guide)

41	00	05	No. of Poles (P)	Terminal Cover Type	
 Solder Model	 Bridge Model	 Center Pin Model			
-	BP100S (2-pole only)	BP105S	2 to 20	A	
	-	-	-	-	
	-	-	2 to 20	-	
	BP100 (2-pole only)	BP105	2 to 20	A	
	-	-	-	-	
	-	-	2 to 20	-	
BP241S	-	BP205S	2 to 18	A	
BP241M		-	-	-	
BP241		BP205	2 to 18	A	
BP241L		-	-	-	
BP241L		-	2 to 18	B	
BP341S		-	BP305S	2 to 18	B
BP341M			-	2 to 18	B
BP341			BP305	2 to 18	B
BP341L	-		2 to 18	B	

Applicable Terminal Covers

Shape	Terminal Centers	No. of Poles																		
		2	3	4	5	6	7	8	9	10	11	12	13	14	15	16	17	18	19	20
BP1	7.62	A																		
	9.5	-	-	-	-	-	-	-	-	-	-	-	-	-	-	-	-	-	-	-
	10	A																		
	11	-	-	-	-	-	-	-	-	-	-	-	-	-	-	-	-	-	-	-
BP2	7.62	A																		
	9.5	B																		
	10	A																		
	11	B																		
BP3	7.62	B																		
	9.5	B																		
	10	B																		
	11	B																		

A : No. of poles for which terminal cover type A is available (see illustrations on the right).
 B : No. of poles for which terminal cover type B is available (see illustrations on the right).
 / : Not available
 - : No. of poles available (terminal covers are not available).

Terminal Cover Types

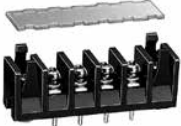
Terminal Cover Type	Appearance
A	<ul style="list-style-type: none"> Hinged Terminal Cover (BPA-CA□SP, -CA□P) 
B	<ul style="list-style-type: none"> Removable Terminal Cover (BPA-C1) 

PC Board Terminal Blocks

Common Specifications (BP1 to BP3)

Terminal Centers	S = 7.62 mm		M = 9.5 mm	10 mm (Note 3)	L = 11 mm
Rated Insulation Voltage	250V				
Rated Current	10A (Note 1)		15A (Note 2)		20A
Terminal Screw	M3		M3.5		M4
Tightening Torque	0.6 to 1.0 N·m		1.0 to 1.3 N·m		1.4 to 2.0 N·m
Connectable Wire	Screw Terminal	0.75 to 1.25 mm ² × 2		0.75 to 2 mm ² × 2	
	Solder Terminal	1.25 mm ² max.		2 mm ² max.	
	Tab Terminal	1.25 mm ² max.		1.25 mm ² max.	
Insulation Resistance	100 MΩ minimum (between live parts and between live and grounded parts)				
Dielectric Strength	2,000V AC, 1 minute				
Impulse Withstand Voltage	4,000V DC (standard wave 1 × 40 μsec)				
Temperature Rise	45 deg maximum				
Vibration Resistance	50 m/s ²				
Shock Resistance	1,000 m/s ²				
Operating Temperature	-10 to +55°C (no freezing)				
Operating Humidity	45 to 85% RH (no condensation)				
Storage Temperature	-40 to +80°C (no freezing)				
Soldering Temperature	Within 5 sec at 260°C (flow soldering) Within 5 sec with a 60W soldering iron at 350°C (manual soldering)				
Body Color	Black (approx. N1.5)				
Weight (Approx.)	40g (20-pole)		72g (20-pole)	80g (20-pole)	122g (20-pole)
Applicable Crimping Terminal					

Note 1 : 6A for the rear tab terminal model

Note 2 : 10A for the rear tab terminal model

Note 3 : BP101V model has the same specifications as the 10-mm model.

Common Specifications (BL2 series Double-deck Terminal Blocks)

Terminal Centers	7.62 mm		8.5 mm	10 mm
Rated Insulation Voltage	250V			
Rated Current	10A		15A	20A
Terminal Screw	M3		M3.5	M4
Connectable Wire	Screw Terminal	0.75 to 1.25 mm ² × 2 max.		0.75 to 2 mm ² × 2 max.
	Terminal	0.75 to 1.25 mm ² × 2 max.		0.75 to 3.5 mm ² × 2 max.
Insulation Resistance	100 MΩ minimum (between live parts and between live and grounded parts)			
Dielectric Strength	2,000V AC, 1 minute			
Impulse Withstand Voltage	4,000V DC (standard wave 1 × 40 μsec)			
Temperature Rise	45 degree C maximum			
Vibration Resistance	50 m/s ²			
Shock Resistance	1000 m/s ²			
Operating Temperature	-10 to +55°C (no freezing)			
Operating Humidity	45 to 85% RH (no condensation)			
Storage Temperature	-40 to +80°C (no freezing)			
Soldering Temperature	Within 5 sec at 260°C (flow soldering) Within 5 sec with a 60W soldering iron at 350°C (manual soldering)			
Body Color	Black (approx. N1.5)			
Weight (Approx.)	105g (34-pole)		130g (34-pole)	150g (34-pole)
Applicable Crimping Terminal				

Material Composition (BP1 to BP3)

Parts Name	Material (Treatment)
Body	PBT, UL94 V-0
Terminal Fitting	Brass (tin-plated)
Terminal Screw	Copper (nickel-plated)

PC Board Terminal Blocks

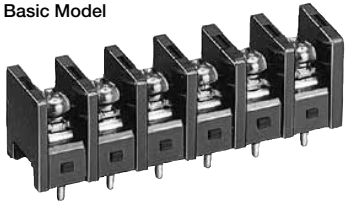
BP1 	Terminal Centers 7.62 mm	BP101S	Specifications <table border="1"> <tr> <td>Terminal Centers</td> <td>S = 7.62 mm</td> <td>M = 9.5 mm</td> <td>10 mm</td> <td>L = 11 mm</td> </tr> <tr> <td>Insulation Voltage</td> <td colspan="4">250V</td> </tr> <tr> <td>Rated Current</td> <td>10A</td> <td>15A</td> <td colspan="2">20A</td> </tr> <tr> <td>Terminal Screw</td> <td>M3</td> <td colspan="2">M3.5</td> <td>M4</td> </tr> <tr> <td>Tightening Torque</td> <td>0.6 to 1.0 N·m</td> <td colspan="2">1.0 to 1.3 N·m</td> <td>1.4 to 2.0 N·m</td> </tr> <tr> <td>No. of Poles (P)</td> <td>2 to 20</td> <td>2 to 20</td> <td>2 to 20</td> <td>2 to 20</td> </tr> <tr> <td>Terminal Cover Type</td> <td>A</td> <td>-</td> <td>A</td> <td>-</td> </tr> </table>	Terminal Centers	S = 7.62 mm	M = 9.5 mm	10 mm	L = 11 mm	Insulation Voltage	250V				Rated Current	10A	15A	20A		Terminal Screw	M3	M3.5		M4	Tightening Torque	0.6 to 1.0 N·m	1.0 to 1.3 N·m		1.4 to 2.0 N·m	No. of Poles (P)	2 to 20	2 to 20	2 to 20	2 to 20	Terminal Cover Type	A	-	A	-
	Terminal Centers	S = 7.62 mm		M = 9.5 mm	10 mm	L = 11 mm																																
	Insulation Voltage	250V																																				
	Rated Current	10A		15A	20A																																	
Terminal Screw	M3	M3.5		M4																																		
Tightening Torque	0.6 to 1.0 N·m	1.0 to 1.3 N·m		1.4 to 2.0 N·m																																		
No. of Poles (P)	2 to 20	2 to 20	2 to 20	2 to 20																																		
Terminal Cover Type	A	-	A	-																																		
Terminal Centers 9.5 mm	BP101M																																					
Terminal Centers 10 mm	BP101																																					
Terminal Centers 11 mm	BP101L																																					

Terminal Centers 7.62 mm	BP101S-□	
--------------------------	----------	---

Dimensions

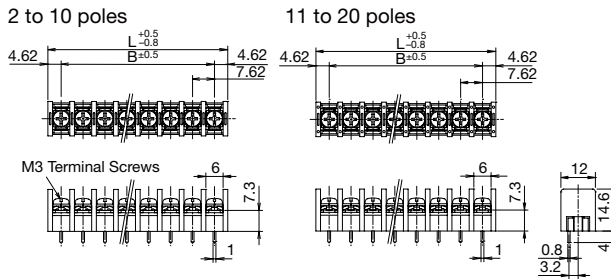

PC Board Drilling Layout (P: No. of Poles)

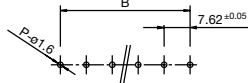

Applicable Crimping Terminal

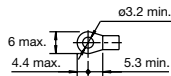

Terminal Centers 9.5 mm	BP101M-□	
-------------------------	----------	---

Dimensions

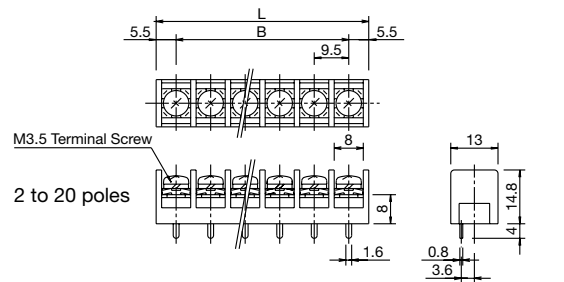

PC Board Drilling Layout (P: No. of Poles)

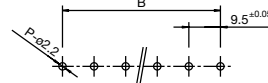

Applicable Crimping Terminal

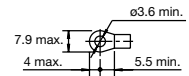

Terminal Centers 10 mm	BP101-□	
------------------------	---------	---

Dimensions

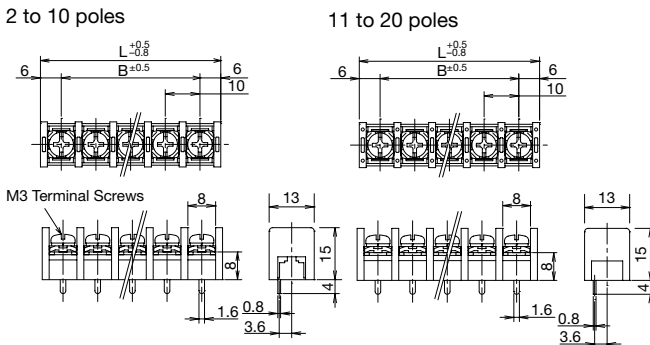

PC Board Drilling Layout (P: No. of Poles)

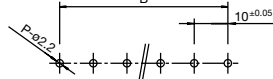

Applicable Crimping Terminal

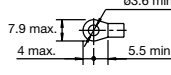

Terminal Centers 11 mm	BP101L-□	
------------------------	----------	---

Dimensions

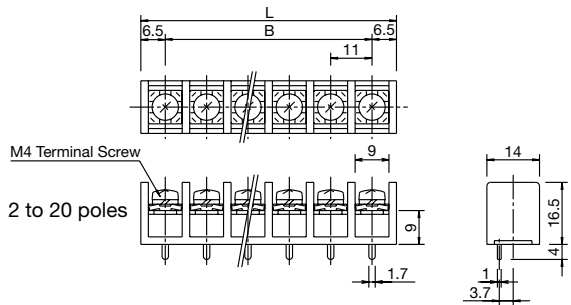

PC Board Drilling Layout (P: No. of Poles)

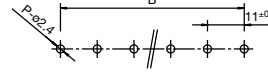

Applicable Crimping Terminal

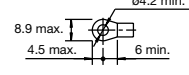

Dimension Formula

Part No.	Dimension	Formula (P: No. of Poles)
BP101S	$L \begin{smallmatrix} +0.5 \\ -0.8 \end{smallmatrix}$	$7.62 \times (P - 1) + 9.24$
	$B \pm 0.5$	$7.62 \times (P - 1)$
BP101	$L \begin{smallmatrix} +0.5 \\ -0.8 \end{smallmatrix}$	$10 \times (P - 1) + 12$
	$B \pm 0.5$	$10 \times (P - 1)$

Dimension Formula

Part No.	Dimension	Formula (P: No. of Poles)
BP101M	$L \begin{smallmatrix} +0.5 \\ -0.8 \end{smallmatrix}$	$9.5 \times (P - 1) + 11$
	$B \pm 0.5$	$9.5 \times (P - 1)$
BP101L	$L \begin{smallmatrix} +0.5 \\ -0.8 \end{smallmatrix}$	$11 \times (P - 1) + 13$
	$B \pm 0.5$	$11 \times (P - 1)$

PC Board Terminal Blocks

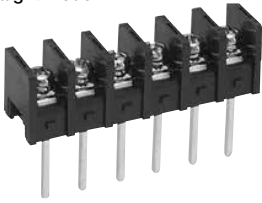
BP1 Straight Model 	Terminal Centers	7.62 mm	BP111S	Specifications <table border="1"> <tr> <td>Terminal Centers</td> <td>S = 7.62 mm</td> <td>M = 9.5 mm</td> <td>10 mm</td> <td>L = 11 mm</td> </tr> <tr> <td>Insulation Voltage</td> <td colspan="4">250V</td> </tr> <tr> <td>Rated Current</td> <td>10A</td> <td>15A</td> <td colspan="2">20A</td> </tr> <tr> <td>Terminal Screw</td> <td>M3</td> <td>M3.5</td> <td colspan="2">M4</td> </tr> <tr> <td>Tightening Torque</td> <td>0.6 to 1.0 N·m</td> <td colspan="2">1.0 to 1.3 N·m</td> <td>1.4 to 2.0 N·m</td> </tr> <tr> <td>No. of Poles (P)</td> <td>2 to 20</td> <td>2 to 20</td> <td>2 to 20</td> <td>2 to 21</td> </tr> <tr> <td>Terminal Cover Type</td> <td>A</td> <td>-</td> <td colspan="2">A</td> </tr> </table> Note: For details of terminal cover types, see Applicable Terminal Covers (page 3).	Terminal Centers	S = 7.62 mm	M = 9.5 mm	10 mm	L = 11 mm	Insulation Voltage	250V				Rated Current	10A	15A	20A		Terminal Screw	M3	M3.5	M4		Tightening Torque	0.6 to 1.0 N·m	1.0 to 1.3 N·m		1.4 to 2.0 N·m	No. of Poles (P)	2 to 20	2 to 20	2 to 20	2 to 21	Terminal Cover Type	A	-	A	
	Terminal Centers	S = 7.62 mm	M = 9.5 mm		10 mm	L = 11 mm																																	
	Insulation Voltage	250V																																					
	Rated Current	10A	15A		20A																																		
Terminal Screw	M3	M3.5	M4																																				
Tightening Torque	0.6 to 1.0 N·m	1.0 to 1.3 N·m		1.4 to 2.0 N·m																																			
No. of Poles (P)	2 to 20	2 to 20	2 to 20	2 to 21																																			
Terminal Cover Type	A	-	A																																				
Terminal Centers	9.5 mm	BP111M																																					
Terminal Centers	10 mm	BP111																																					
Terminal Centers	11 mm	BP111L																																					

Terminal Centers	7.62 mm	BP111S-□	
------------------	---------	----------	---

Dimensions

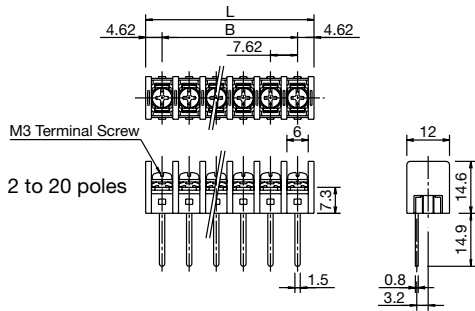

PC Board Drilling Layout (P: No. of Poles)

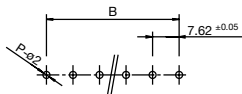

Applicable Crimping Terminal

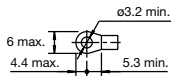

Terminal Centers	10 mm	BP111-□	
------------------	-------	---------	---

Dimensions

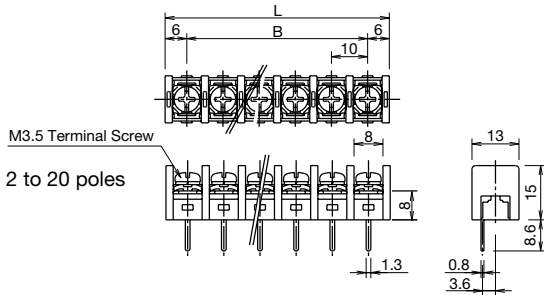

PC Board Drilling Layout (P: No. of Poles)

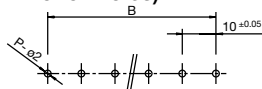

Applicable Crimping Terminal

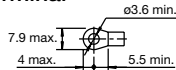

Dimension Formula

Part No.	Dimension	Formula (P: No. of Poles)
BP111S	L ^{+0.5} _{-0.8}	7.62 × (P - 1) + 9.24
	B ^{+0.5}	7.62 × (P - 1)
BP111	L ^{+0.5} _{-0.8}	10 × (P - 1) + 12
	B ^{+0.5}	10 × (P - 1)

Terminal Centers	9.5 mm	BP111M-□□	
------------------	--------	-----------	---

Dimensions

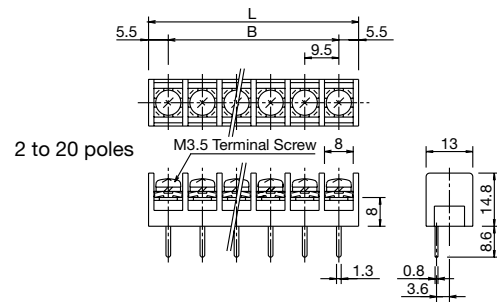

PC Board Drilling Layout (P: No. of Poles)

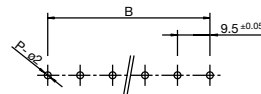

Applicable Crimping Terminal

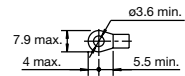

Terminal Centers	11 mm	BP111L-□	
------------------	-------	----------	---

Dimensions

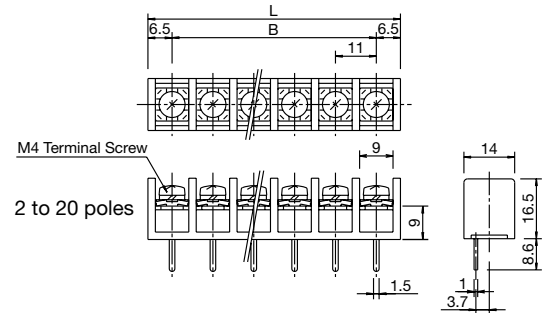

PC Board Drilling Layout (P: No. of Poles)

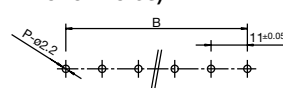

Applicable Crimping Terminal

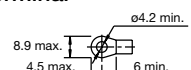

Dimension Formula

Part No.	Dimension	Formula (P: No. of Poles)
BP111M	L ^{+0.5} _{-0.8}	9.5 × (P - 1) + 11
	B ^{+0.5}	9.5 × (P - 1)
BP111L	L ^{+0.5} _{-0.8}	11 × (P - 1) + 13
	B ^{+0.5}	11 × (P - 1)

PC Board Terminal Blocks

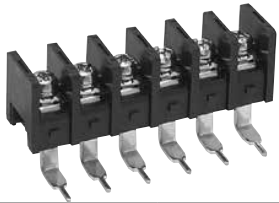
BP1 Right-angle Model 	Terminal Centers 7.62 mm	BP121S	Specifications				
	Terminal Centers 9.5 mm	BP121M	Terminal Centers	S = 7.62 mm	M = 9.5 mm	10 mm	L = 11 mm
	Terminal Centers 10 mm	BP121	Insulation Voltage	250V			
	Terminal Centers 11 mm	BP121L	Rated Current	10A	15A	20A	
			Terminal Screw	M3	M3.5	M4	
			Tightening Torque	0.6 to 1.0 N·m	1.0 to 1.3 N·m	1.4 to 2.0 N·m	
			No. of Poles (P)	2 to 20	2 to 20	2 to 20	2 to 20
			Terminal Cover Type	A	-	A	-
			Note: For details of terminal cover types, see Applicable Terminal Covers (page 3).				

Terminal Centers 7.62 mm	BP121S-□	M3
--------------------------	----------	----

Dimensions

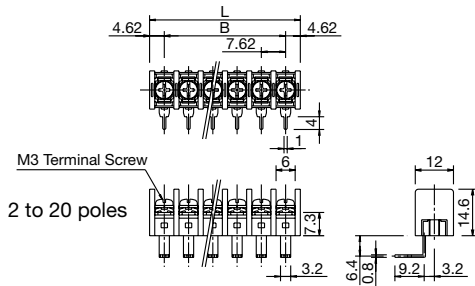

PC Board Drilling Layout (P: No. of Poles)

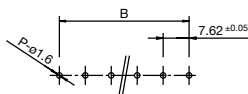

Applicable Crimping Terminal

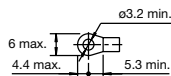

Terminal Centers 10 mm	BP121-□	M3.5
------------------------	---------	------

Dimensions

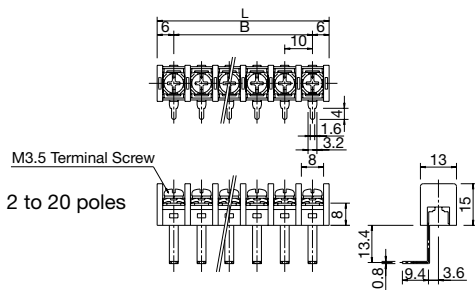

PC Board Drilling Layout (P: No. of Poles)

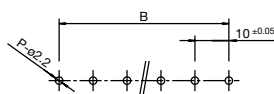

Applicable Crimping Terminal

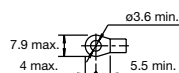

Dimension Formula

Part No.	Dimension	Formula (P: No. of Poles)
BP121S	L ^{+0.5} / _{-0.8}	7.62 × (P - 1) + 9.24
	B ^{±0.5}	7.62 × (P - 1)
BP121	L ^{+0.5} / _{-0.8}	10 × (P - 1) + 12
	B ^{±0.5}	10 × (P - 1)

Terminal Centers 9.5 mm	BP121M-□	M3.5
-------------------------	----------	------

Dimensions

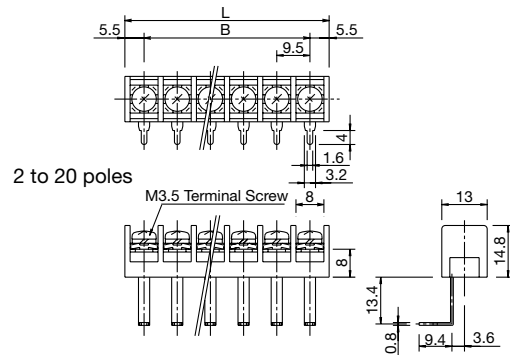

PC Board Drilling Layout (P: No. of Poles)

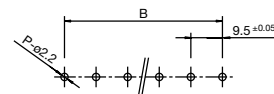

Applicable Crimping Terminal

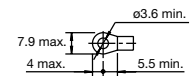

Terminal Centers 11 mm	BP121L-□	M4
------------------------	----------	----

Dimensions

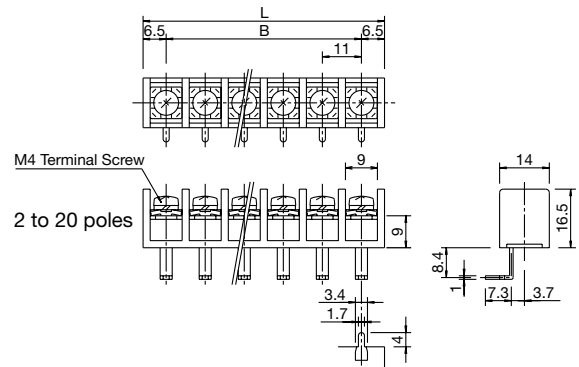

PC Board Drilling Layout (P: No. of Poles)

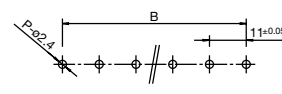

Applicable Crimping Terminal

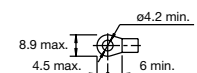



Dimension Formula

Part No.	Dimension	Formula (P: No. of Poles)
BP121M	L ^{+0.5} / _{-0.8}	9.5 × (P - 1) + 11
	B ^{±0.5}	9.5 × (P - 1)
BP121L	L ^{+0.5} / _{-0.8}	11 × (P - 1) + 13
	B ^{±0.5}	11 × (P - 1)

PC Board Terminal Blocks

BP1 Bridge Model 	Terminal Centers 7.62 mm	BP100S	Specifications <table border="1"> <tr> <td>Terminal Centers</td> <td>S = 7.62 mm</td> <td>10 mm</td> </tr> <tr> <td>Insulation Voltage</td> <td colspan="2">250V</td> </tr> <tr> <td>Rated Current</td> <td>10A</td> <td>15A</td> </tr> <tr> <td>Terminal Screw</td> <td>M3</td> <td>M3.5</td> </tr> <tr> <td>Tightening Torque</td> <td>0.6 to 1.0 N·m</td> <td>1.0 to 1.3 N·m</td> </tr> <tr> <td>No. of Poles (P)</td> <td colspan="2">2 poles only</td> </tr> <tr> <td>Terminal Cover Type</td> <td colspan="2">A</td> </tr> </table> Note: For details of terminal cover types, see Applicable Terminal Covers (page 3).	Terminal Centers	S = 7.62 mm	10 mm	Insulation Voltage	250V		Rated Current	10A	15A	Terminal Screw	M3	M3.5	Tightening Torque	0.6 to 1.0 N·m	1.0 to 1.3 N·m	No. of Poles (P)	2 poles only		Terminal Cover Type	A	
	Terminal Centers	S = 7.62 mm		10 mm																				
Insulation Voltage	250V																							
Rated Current	10A	15A																						
Terminal Screw	M3	M3.5																						
Tightening Torque	0.6 to 1.0 N·m	1.0 to 1.3 N·m																						
No. of Poles (P)	2 poles only																							
Terminal Cover Type	A																							
Terminal Centers 10 mm	BP100																							

Terminal Centers 7.62 mm	BP100S-2	
--------------------------	----------	---

Terminal Centers 10 mm	BP100-2	
------------------------	---------	---

Dimensions

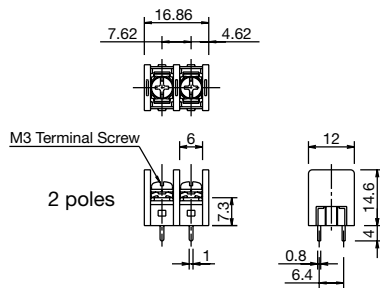

Dimensions

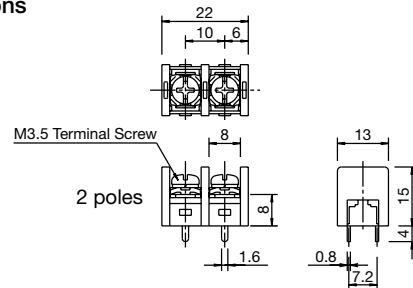

PC Board Drilling Layout (P: No. of Poles)

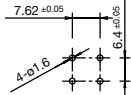

Applicable Crimping Terminal

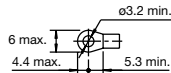

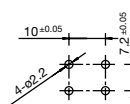

PC Board Drilling Layout (P: No. of Poles)

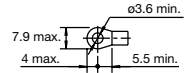

Applicable Crimping Terminal



BP1 Center Pin Model 	Terminal Centers 7.62 mm	BP105S	Specifications <table border="1"> <tr> <td>Terminal Centers</td> <td>S = 7.62 mm</td> <td>10 mm</td> </tr> <tr> <td>Insulation Voltage</td> <td colspan="2">250V</td> </tr> <tr> <td>Rated Current</td> <td>10A</td> <td>15A</td> </tr> <tr> <td>Terminal Screw</td> <td>M3</td> <td>M3.5</td> </tr> <tr> <td>Tightening Torque</td> <td>0.6 to 1.0 N·m</td> <td>1.0 to 1.3 N·m</td> </tr> <tr> <td>No. of Poles (P)</td> <td colspan="2">2 to 20</td> </tr> <tr> <td>Terminal Cover Type</td> <td colspan="2">A</td> </tr> </table> Note: For details of terminal cover types, see Applicable Terminal Covers (page 3).	Terminal Centers	S = 7.62 mm	10 mm	Insulation Voltage	250V		Rated Current	10A	15A	Terminal Screw	M3	M3.5	Tightening Torque	0.6 to 1.0 N·m	1.0 to 1.3 N·m	No. of Poles (P)	2 to 20		Terminal Cover Type	A	
	Terminal Centers	S = 7.62 mm		10 mm																				
Insulation Voltage	250V																							
Rated Current	10A	15A																						
Terminal Screw	M3	M3.5																						
Tightening Torque	0.6 to 1.0 N·m	1.0 to 1.3 N·m																						
No. of Poles (P)	2 to 20																							
Terminal Cover Type	A																							
Terminal Centers 10 mm	BP105																							

Terminal Centers 7.62 mm	BP105S-□	
--------------------------	----------	---

Terminal Centers 10 mm	BP105-□	
------------------------	---------	---

Dimensions

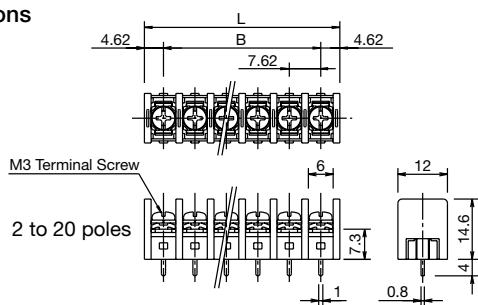

Dimensions

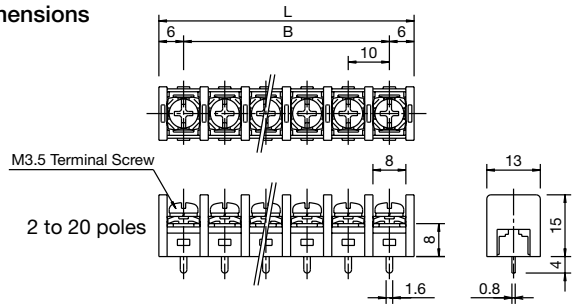

PC Board Drilling Layout (P: No. of Poles)

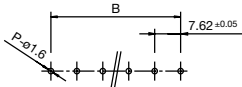

Applicable Crimping Terminal

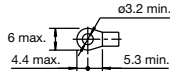

PC Board Drilling Layout (P: No. of Poles)

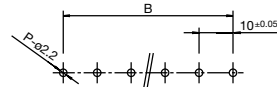

Applicable Crimping Terminal

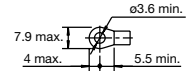

Dimension Formula

Part No.	Dimension	Formula (P: No. of Poles)
BP105S	L $^{+0.5}_{-0.8}$	$7.62 \times (P - 1) + 9.24$
	B $^{+0.5}$	$7.62 \times (P - 1)$

Dimension Formula

Part No.	Dimension	Formula (P: No. of Poles)
BP105	L $^{+0.5}_{-0.8}$	$10 \times (P - 1) + 12$
	B $^{+0.5}$	$10 \times (P - 1)$

PC Board Terminal Blocks

BP2 Basic Model 	Terminal Centers 7.62 mm	BP201S	Specifications <table border="1"> <tr> <td>Terminal Centers</td> <td>S = 7.62 mm</td> <td>M = 9.5 mm</td> <td>10 mm</td> <td>L = 11 mm</td> </tr> <tr> <td>Insulation Voltage</td> <td colspan="4">250V</td> </tr> <tr> <td>Rated Current</td> <td>10A</td> <td>15A</td> <td colspan="2">20A</td> </tr> <tr> <td>Terminal Screw</td> <td>M3</td> <td>M3.5</td> <td colspan="2">M4</td> </tr> <tr> <td>Tightening Torque</td> <td>0.6 to 1.0 N·m</td> <td>1.0 to 1.3 N·m</td> <td colspan="2">1.4 to 2.0 N·m</td> </tr> <tr> <td>No. of Poles (P)</td> <td>2 to 18</td> <td>2 to 18</td> <td>2 to 18</td> <td>2 to 18</td> </tr> <tr> <td>Terminal Cover Type</td> <td>A</td> <td>B</td> <td>A</td> <td>B</td> </tr> </table> Note: For details of terminal cover types, see Applicable Terminal Covers (page 3).	Terminal Centers	S = 7.62 mm	M = 9.5 mm	10 mm	L = 11 mm	Insulation Voltage	250V				Rated Current	10A	15A	20A		Terminal Screw	M3	M3.5	M4		Tightening Torque	0.6 to 1.0 N·m	1.0 to 1.3 N·m	1.4 to 2.0 N·m		No. of Poles (P)	2 to 18	2 to 18	2 to 18	2 to 18	Terminal Cover Type	A	B	A	B
	Terminal Centers	S = 7.62 mm		M = 9.5 mm	10 mm	L = 11 mm																																
	Insulation Voltage	250V																																				
	Rated Current	10A		15A	20A																																	
Terminal Screw	M3	M3.5	M4																																			
Tightening Torque	0.6 to 1.0 N·m	1.0 to 1.3 N·m	1.4 to 2.0 N·m																																			
No. of Poles (P)	2 to 18	2 to 18	2 to 18	2 to 18																																		
Terminal Cover Type	A	B	A	B																																		
Terminal Centers 9.5 mm	BP201M																																					
Terminal Centers 10 mm	BP201																																					
Terminal Centers 11 mm	BP201L																																					

Terminal Centers 7.62 mm	BP201S-□	M3
--------------------------	----------	----

Dimensions

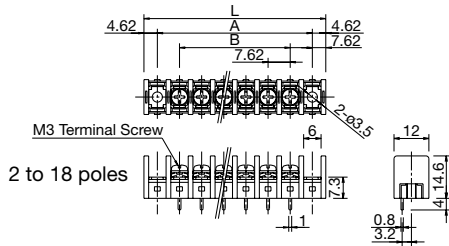

PC Board Drilling Layout (P: No. of Poles)

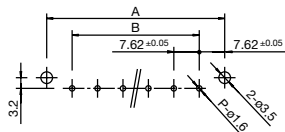

Applicable Crimping Terminal

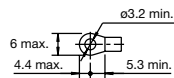

Terminal Centers 9.5 mm	BP201M-□	M3.5
-------------------------	----------	------

Dimensions

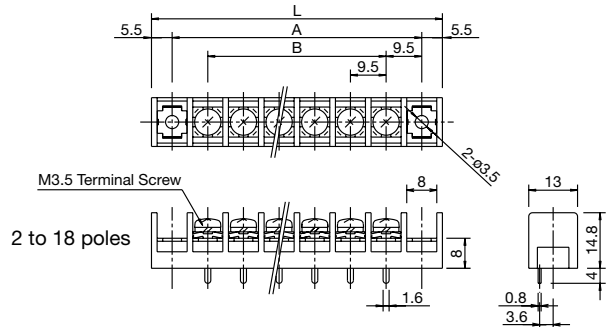

PC Board Drilling Layout (P: No. of Poles)

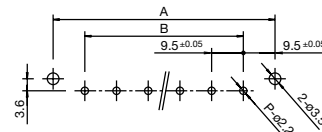

Applicable Crimping Terminal

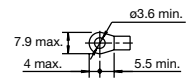

Terminal Centers 10 mm	BP201-□	M3.5
------------------------	---------	------

Dimensions

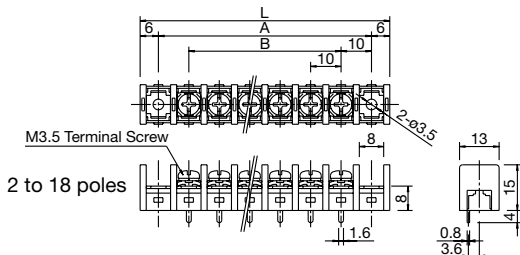

PC Board Drilling Layout (P: No. of Poles)

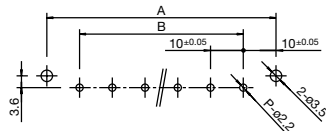

Applicable Crimping Terminal

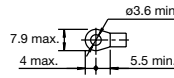

Terminal Centers 11 mm	BP201L-□	M4
------------------------	----------	----

Dimensions

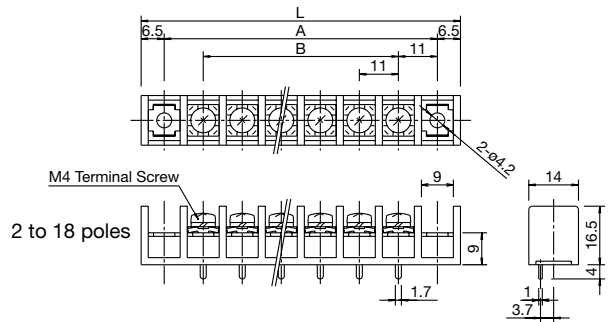

PC Board Drilling Layout (P: No. of Poles)

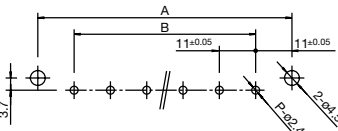

Applicable Crimping Terminal

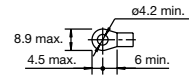

Dimension Formula

Part No.	Dimension	Formula (P: No. of Poles)
BP201S	L ^{+0.5} / _{-0.8}	7.62 × (P + 1) + 9.24
	A ^{±0.5}	7.62 × (P + 1)
	B	7.62 × (P - 1)
BP201	L ^{+0.5} / _{-0.8}	10 × (P + 1) + 12
	A ^{±0.5}	10 × (P + 1)
	B	10 × (P - 1)

Dimension Formula

Part No.	Dimension	Formula (P: No. of Poles)
BP201M	L ^{+0.5} / _{-0.8}	9.5 × (P + 1) + 11
	A ^{±0.5}	9.5 × (P + 1)
	B	9.5 × (P - 1)
BP201L	L ^{+0.5} / _{-0.8}	11 × (P + 1) + 13
	A ^{±0.5}	11 × (P + 1)
	B	11 × (P - 1)

PC Board Terminal Blocks

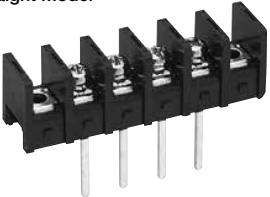
BP2 Straight Model 	Terminal Centers 7.62 mm	BP211S	Specifications <table border="1"> <tr> <td>Terminal Centers</td> <td>S = 7.62 mm</td> <td>M = 9.5 mm</td> <td>10 mm</td> <td>L = 11 mm</td> </tr> <tr> <td>Insulation Voltage</td> <td colspan="4">250V</td> </tr> <tr> <td>Rated Current</td> <td>10A</td> <td>15A</td> <td colspan="2">20A</td> </tr> <tr> <td>Terminal Screw</td> <td>M3</td> <td colspan="2">M3.5</td> <td>M4</td> </tr> <tr> <td>Tightening Torque</td> <td>0.6 to 1.0 N·m</td> <td colspan="2">1.0 to 1.3 N·m</td> <td>1.4 to 2.0 N·m</td> </tr> <tr> <td>No. of Poles (P)</td> <td>2 to 18</td> <td>2 to 18</td> <td>2 to 18</td> <td>2 to 18</td> </tr> <tr> <td>Terminal Cover Type</td> <td>A</td> <td>B</td> <td>A</td> <td>B</td> </tr> </table> Note: For details of terminal cover types, see Applicable Terminal Covers (page 3).	Terminal Centers	S = 7.62 mm	M = 9.5 mm	10 mm	L = 11 mm	Insulation Voltage	250V				Rated Current	10A	15A	20A		Terminal Screw	M3	M3.5		M4	Tightening Torque	0.6 to 1.0 N·m	1.0 to 1.3 N·m		1.4 to 2.0 N·m	No. of Poles (P)	2 to 18	2 to 18	2 to 18	2 to 18	Terminal Cover Type	A	B	A	B
	Terminal Centers	S = 7.62 mm		M = 9.5 mm	10 mm	L = 11 mm																																
	Insulation Voltage	250V																																				
	Rated Current	10A		15A	20A																																	
Terminal Screw	M3	M3.5		M4																																		
Tightening Torque	0.6 to 1.0 N·m	1.0 to 1.3 N·m		1.4 to 2.0 N·m																																		
No. of Poles (P)	2 to 18	2 to 18	2 to 18	2 to 18																																		
Terminal Cover Type	A	B	A	B																																		
Terminal Centers 9.5 mm	BP211M																																					
Terminal Centers 10 mm	BP211																																					
Terminal Centers 11 mm	BP211L																																					

Terminal Centers 7.62 mm	BP211S-□	M3
--------------------------	----------	----

Dimensions

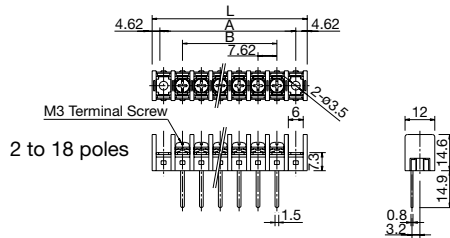

PC Board Drilling Layout (P: No. of Poles)

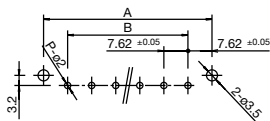

Applicable Crimping Terminal

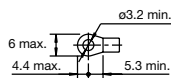

Terminal Centers 10 mm	BP211-□	M3.5
------------------------	---------	------

Dimensions

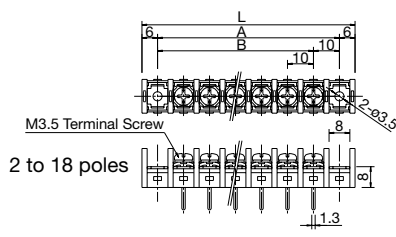

PC Board Drilling Layout (P: No. of Poles)

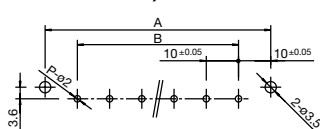

Applicable Crimping Terminal

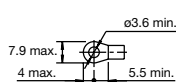

Dimension Formula

Part No.	Dimension	Formula (P: No. of Poles)
BP211S	L ^{+0.5/-0.8}	7.62 × (P + 1) + 9.24
	A ^{+0.5}	7.62 × (P + 1)
	B	7.62 × (P - 1)
BP211	L ^{+0.5/-0.8}	10 × (P + 1) + 12
	A ^{+0.5}	10 × (P + 1)
	B	10 × (P - 1)

Terminal Centers 9.5 mm	BP211M-□	M3.5
-------------------------	----------	------

Dimensions

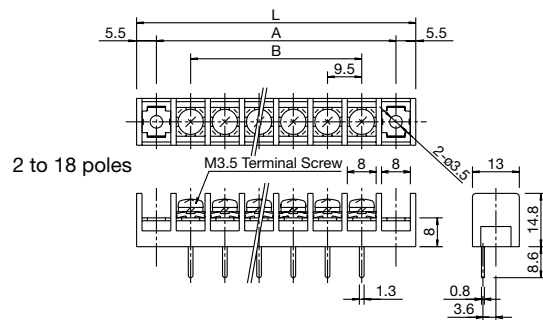

PC Board Drilling Layout (P: No. of Poles)

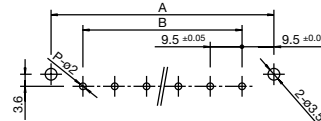

Applicable Crimping Terminal

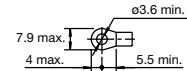

Terminal Centers 11 mm	BP211L-□	M4
------------------------	----------	----

Dimensions

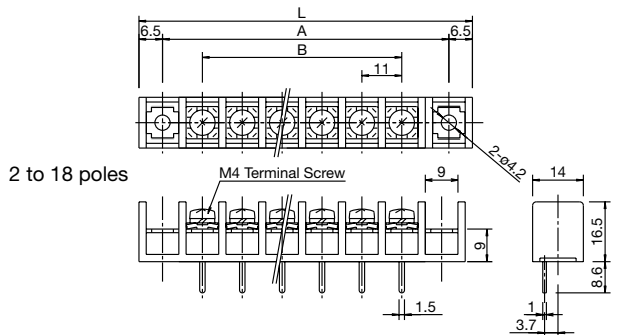

PC Board Drilling Layout (P: No. of Poles)

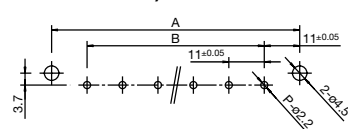

Applicable Crimping Terminal

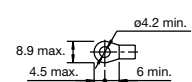

Dimension Formula

Part No.	Dimension	Formula (P: No. of Poles)
BP211M	L ^{+0.5/-0.8}	9.5 × (P + 1) + 11
	A ^{+0.5}	9.5 × (P + 1)
	B	9.5 × (P - 1)
BP211L	L ^{+0.5/-0.8}	11 × (P + 1) + 13
	A ^{+0.5}	11 × (P + 1)
	B	11 × (P - 1)

PC Board Terminal Blocks

BP2 Right-angle Model 	Terminal Centers 7.62 mm	BP221S	Specifications <table border="1"> <tr> <td>Terminal Centers</td> <td>S = 7.62 mm</td> <td>M = 9.5 mm</td> <td>10 mm</td> <td>L = 11 mm</td> </tr> <tr> <td>Insulation Voltage</td> <td colspan="4">250V</td> </tr> <tr> <td>Rated Current</td> <td>10A</td> <td>15A</td> <td colspan="2">20A</td> </tr> <tr> <td>Terminal Screw</td> <td>M3</td> <td colspan="2">M3.5</td> <td>M4</td> </tr> <tr> <td>Tightening Torque</td> <td>0.6 to 1.0 N·m</td> <td colspan="2">1.0 to 1.3 N·m</td> <td>1.4 to 2.0 N·m</td> </tr> <tr> <td>No. of Poles (P)</td> <td>2 to 18</td> <td>2 to 18</td> <td>2 to 18</td> <td>2 to 18</td> </tr> <tr> <td>Terminal Cover Type</td> <td>A</td> <td>B</td> <td>A</td> <td>B</td> </tr> </table> Note: For details of terminal cover types, see Applicable Terminal Covers (page 3).	Terminal Centers	S = 7.62 mm	M = 9.5 mm	10 mm	L = 11 mm	Insulation Voltage	250V				Rated Current	10A	15A	20A		Terminal Screw	M3	M3.5		M4	Tightening Torque	0.6 to 1.0 N·m	1.0 to 1.3 N·m		1.4 to 2.0 N·m	No. of Poles (P)	2 to 18	2 to 18	2 to 18	2 to 18	Terminal Cover Type	A	B	A	B
	Terminal Centers	S = 7.62 mm		M = 9.5 mm	10 mm	L = 11 mm																																
	Insulation Voltage	250V																																				
	Rated Current	10A		15A	20A																																	
Terminal Screw	M3	M3.5		M4																																		
Tightening Torque	0.6 to 1.0 N·m	1.0 to 1.3 N·m		1.4 to 2.0 N·m																																		
No. of Poles (P)	2 to 18	2 to 18	2 to 18	2 to 18																																		
Terminal Cover Type	A	B	A	B																																		
Terminal Centers 9.5 mm	BP221M																																					
Terminal Centers 10 mm	BP221																																					
Terminal Centers 11 mm	BP221L																																					

Terminal Centers 7.62 mm	BP221S-□	
--------------------------	----------	---

Dimensions

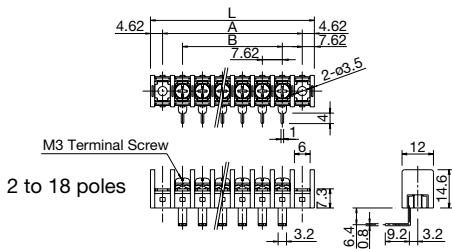

PC Board Drilling Layout (P: No. of Poles)

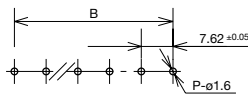

Applicable Crimping Terminal

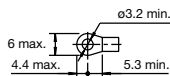

Terminal Centers 10 mm	BP221-□	
------------------------	---------	---

Dimensions

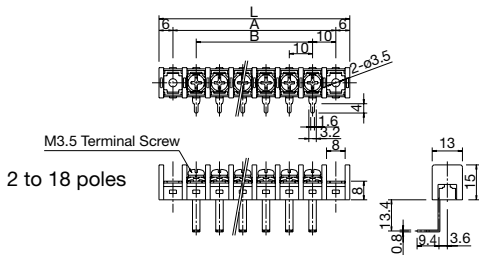

PC Board Drilling Layout (P: No. of Poles)

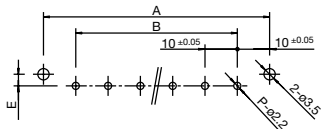

Applicable Crimping Terminal

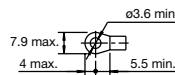

Applicable Right-angle Clip Part No.: BPF-L1

Dimension Formula

Part No.	Dimension	Formula (P: No. of Poles)
BP221S	L	$7.62 \times (P + 1) + 9.24$
	$A \begin{smallmatrix} +0.5 \\ -0.8 \end{smallmatrix}$	$7.62 \times (P + 1)$
	$B \pm 0.5$	$7.62 \times (P - 1)$
BP221	L	$10 \times (P + 1) + 12$
	$A \begin{smallmatrix} +0.5 \\ -0.8 \end{smallmatrix}$	$10 \times (P + 1)$
	$B \pm 0.5$	$10 \times (P - 1)$

Terminal Centers 9.5 mm	BP221M-□	
-------------------------	----------	---

Dimensions

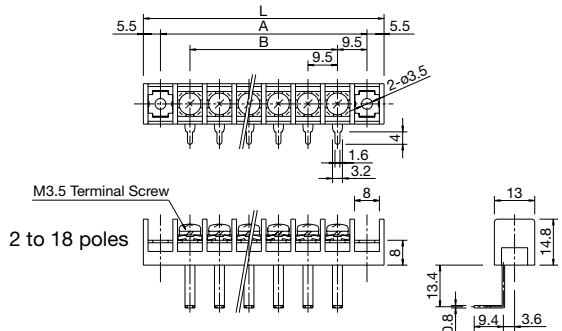

PC Board Drilling Layout (P: No. of Poles)

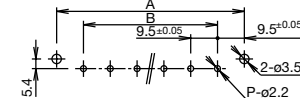

Applicable Crimping Terminal

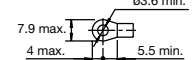

Applicable Right-angle Clip Part No.: BPF-L1

Terminal Centers 11 mm	BP221L-□	
------------------------	----------	---

Dimensions

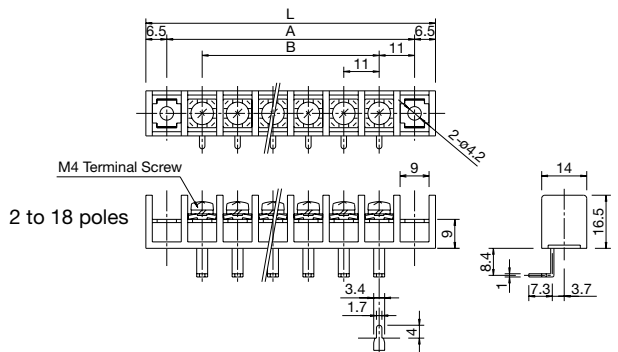

PC Board Drilling Layout (P: No. of Poles)

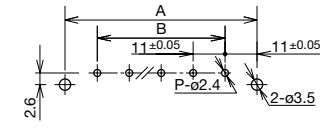

Applicable Crimping Terminal

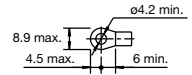



Applicable Right-angle Clip Part No.: BPF-L7

Dimension Formula

Part No.	Dimension	Formula (P: No. of Poles)
BP221M	$L \begin{smallmatrix} +0.5 \\ -0.8 \end{smallmatrix}$	$9.5 \times (P + 1) + 11$
	$A \pm 0.5$	$9.5 \times (P + 1)$
	B	$9.5 \times (P - 1)$
BP221L	$L \begin{smallmatrix} +0.5 \\ -0.8 \end{smallmatrix}$	$11 \times (P + 1) + 13$
	$A \pm 0.5$	$11 \times (P + 1)$
	B	$11 \times (P - 1)$

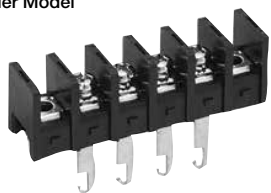
PC Board Terminal Blocks

BP2 	Terminal Centers 7.62 mm	BP241S	Specifications <table border="1"> <tr> <td>Terminal Centers</td> <td>S = 7.62 mm</td> <td>M = 9.5 mm</td> <td>10 mm</td> <td>L = 11 mm</td> </tr> <tr> <td>Insulation Voltage</td> <td colspan="4">250V</td> </tr> <tr> <td>Rated Current</td> <td>10A</td> <td>15A</td> <td>20A</td> <td></td> </tr> <tr> <td>Terminal Screw</td> <td>M3</td> <td>M3.5</td> <td>M4</td> <td></td> </tr> <tr> <td>Tightening Torque</td> <td>0.6 to 1.0 N·m</td> <td>1.0 to 1.3 N·m</td> <td>1.4 to 2.0 N·m</td> <td></td> </tr> <tr> <td>No. of Poles (P)</td> <td>2 to 18</td> <td>2 to 18</td> <td>2 to 18</td> <td>2 to 18</td> </tr> <tr> <td>Terminal Cover Type</td> <td>A</td> <td>B</td> <td>A</td> <td>B</td> </tr> </table> <p>Note: For details of terminal cover types, see Applicable Terminal Covers (page 3).</p>	Terminal Centers	S = 7.62 mm	M = 9.5 mm	10 mm	L = 11 mm	Insulation Voltage	250V				Rated Current	10A	15A	20A		Terminal Screw	M3	M3.5	M4		Tightening Torque	0.6 to 1.0 N·m	1.0 to 1.3 N·m	1.4 to 2.0 N·m		No. of Poles (P)	2 to 18	2 to 18	2 to 18	2 to 18	Terminal Cover Type	A	B	A	B
	Terminal Centers	S = 7.62 mm		M = 9.5 mm	10 mm	L = 11 mm																																
	Insulation Voltage	250V																																				
	Rated Current	10A		15A	20A																																	
Terminal Screw	M3	M3.5	M4																																			
Tightening Torque	0.6 to 1.0 N·m	1.0 to 1.3 N·m	1.4 to 2.0 N·m																																			
No. of Poles (P)	2 to 18	2 to 18	2 to 18	2 to 18																																		
Terminal Cover Type	A	B	A	B																																		
Terminal Centers 9.5 mm	BP241M																																					
Terminal Centers 10 mm	BP241																																					
Terminal Centers 11 mm	BP241L																																					

Terminal Centers 7.62 mm	BP241S-□	
--------------------------	----------	---

Dimensions

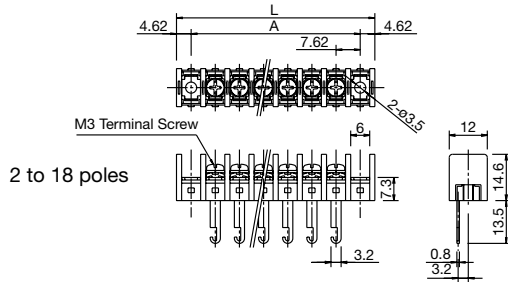

Applicable Crimping Terminal

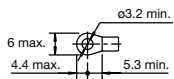

Terminal Centers 10 mm	BP241-□	
------------------------	---------	---

Dimensions

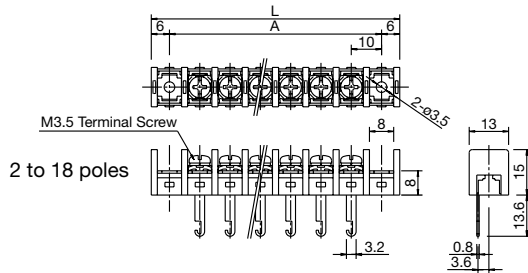

Applicable Crimping Terminal

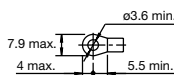

Dimension Formula

Part No.	Dimension	Formula (P: No. of Poles)
BP241S	L ^{+0.5} _{-0.8}	7.62 × (P + 1) + 9.24
	A ^{+0.5}	7.62 × (P + 1)
BP241	L ^{+0.5} _{-0.8}	10 × (P + 1) + 12
	A ^{+0.5}	10 × (P + 1)

Terminal Centers 9.5 mm	BP241M-□	
-------------------------	----------	---

Dimensions

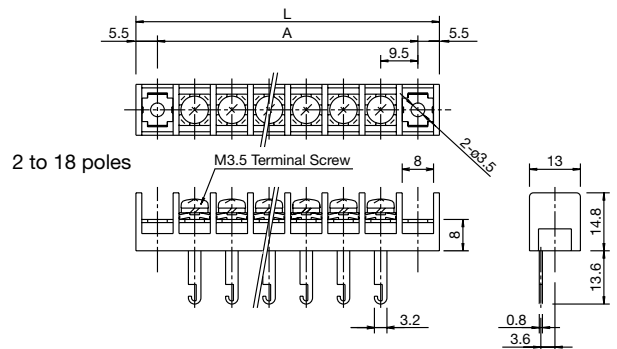

Applicable Crimping Terminal

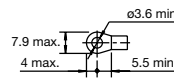

Terminal Centers 11 mm	BP241L-□	
------------------------	----------	---

Dimensions

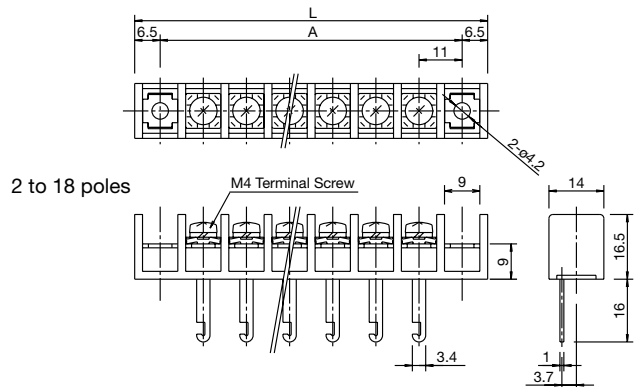

Applicable Crimping Terminal

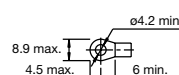

Dimension Formula

Part No.	Dimension	Formula (P: No. of Poles)
BP241M	L ^{+0.5} _{-0.8}	9.5 × (P + 1) + 11
	A ^{+0.5}	9.5 × (P + 1)
BP241L	L ^{+0.5} _{-0.8}	11 × (P + 1) + 13
	A ^{+0.5}	11 × (P + 1)

PC Board Terminal Blocks

BP2 Center Pin Model 	Terminal Centers 7.62 mm	BP205S	Specifications <table border="1"> <tr> <td>Terminal Centers</td> <td>S = 7.62 mm</td> <td>10 mm</td> </tr> <tr> <td>Insulation Voltage</td> <td colspan="2">250V</td> </tr> <tr> <td>Rated Current</td> <td>10A</td> <td>15A</td> </tr> <tr> <td>Terminal Screw</td> <td>M3</td> <td>M3.5</td> </tr> <tr> <td>Tightening Torque</td> <td>0.6 to 1.0 N·m</td> <td>1.0 to 1.3 N·m</td> </tr> <tr> <td>No. of Poles (P)</td> <td>2 to 18</td> <td>2 to 18</td> </tr> <tr> <td>Terminal Cover Type</td> <td>A</td> <td>A</td> </tr> </table> Note: For details of terminal cover types, see Applicable Terminal Covers (page 3).	Terminal Centers	S = 7.62 mm	10 mm	Insulation Voltage	250V		Rated Current	10A	15A	Terminal Screw	M3	M3.5	Tightening Torque	0.6 to 1.0 N·m	1.0 to 1.3 N·m	No. of Poles (P)	2 to 18	2 to 18	Terminal Cover Type	A	A
	Terminal Centers	S = 7.62 mm		10 mm																				
Insulation Voltage	250V																							
Rated Current	10A	15A																						
Terminal Screw	M3	M3.5																						
Tightening Torque	0.6 to 1.0 N·m	1.0 to 1.3 N·m																						
No. of Poles (P)	2 to 18	2 to 18																						
Terminal Cover Type	A	A																						
Terminal Centers 10 mm	BP205																							

Terminal Centers 7.62 mm	BP205S-□	
--------------------------	----------	---

Dimensions

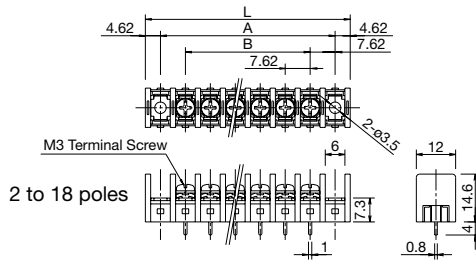

Terminal Centers 10 mm	BP205-□	
------------------------	---------	---

Dimensions

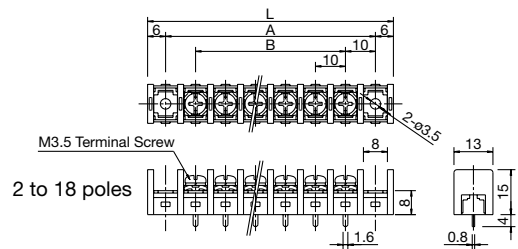

PC Board Drilling Layout (P: No. of Poles)

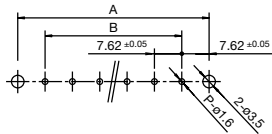

Applicable Crimping Terminal

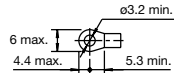

PC Board Drilling Layout (P: No. of Poles)

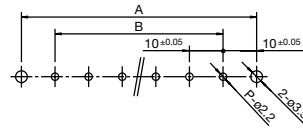

Applicable Crimping Terminal

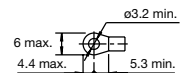

Dimension Formula

Part No.	Dimension	Formula (P: No. of Poles)
BP205S	L ^{+0.5} / _{-0.8}	$7.62 \times (P + 1) + 9.24$
	A ^{±0.5}	$7.62 \times (P + 1)$
	B	$7.62 \times (P - 1)$

Dimension Formula

Part No.	Dimension	Formula (P: No. of Poles)
BP205	L ^{+0.5} / _{-0.8}	$10 \times (P + 1) + 12$
	A ^{±0.5}	$10 \times (P + 1)$
	B	$10 \times (P - 1)$

PC Board Terminal Blocks

BP3 	Terminal Centers 7.62 mm	BP301S	Specifications <table border="1"> <tr> <td>Terminal Centers</td> <td>S = 7.62 mm</td> <td>M = 9.5 mm</td> <td>10 mm</td> <td>L = 11 mm</td> </tr> <tr> <td>Insulation Voltage</td> <td colspan="4">250V</td> </tr> <tr> <td>Rated Current</td> <td>10A</td> <td>15A</td> <td colspan="2">20A</td> </tr> <tr> <td>Terminal Screw</td> <td>M3</td> <td colspan="2">M3.5</td> <td>M4</td> </tr> <tr> <td>Tightening Torque</td> <td>0.6 to 1.0 N·m</td> <td colspan="2">1.0 to 1.3 N·m</td> <td>1.4 to 2.0 N·m</td> </tr> <tr> <td>No. of Poles (P)</td> <td>2 to 18</td> <td>2 to 18</td> <td>2 to 18</td> <td>2 to 18</td> </tr> <tr> <td>Terminal Cover Type</td> <td colspan="4">B</td> </tr> </table>	Terminal Centers	S = 7.62 mm	M = 9.5 mm	10 mm	L = 11 mm	Insulation Voltage	250V				Rated Current	10A	15A	20A		Terminal Screw	M3	M3.5		M4	Tightening Torque	0.6 to 1.0 N·m	1.0 to 1.3 N·m		1.4 to 2.0 N·m	No. of Poles (P)	2 to 18	2 to 18	2 to 18	2 to 18	Terminal Cover Type	B			
	Terminal Centers	S = 7.62 mm		M = 9.5 mm	10 mm	L = 11 mm																																
	Insulation Voltage	250V																																				
	Rated Current	10A		15A	20A																																	
Terminal Screw	M3	M3.5		M4																																		
Tightening Torque	0.6 to 1.0 N·m	1.0 to 1.3 N·m		1.4 to 2.0 N·m																																		
No. of Poles (P)	2 to 18	2 to 18	2 to 18	2 to 18																																		
Terminal Cover Type	B																																					
Terminal Centers 9.5 mm	BP301M																																					
Terminal Centers 10 mm	BP301																																					
Terminal Centers 11 mm	BP301L																																					

Terminal Centers 7.62 mm	BP301S-□	
--------------------------	----------	---

Dimensions

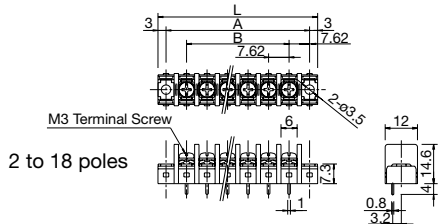

PC Board Drilling Layout (P: No. of Poles)

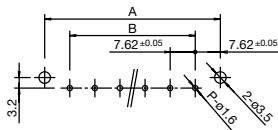

Applicable Crimping Terminal

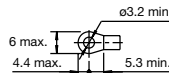

Terminal Centers 10 mm	BP301-□	
------------------------	---------	---

Dimensions

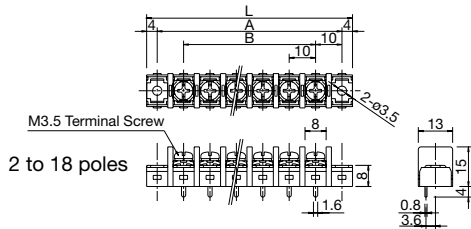

PC Board Drilling Layout (P: No. of Poles)

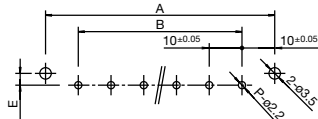

Applicable Crimping Terminal

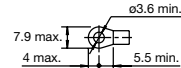

Dimension Formula

Part No.	Dimension	Formula (P: No. of Poles)
BP301S	L ^{+0.8/-0.3}	7.62 × (P + 1) + 6
	A ^{+0.5}	7.62 × (P + 1)
	B	7.62 × (P - 1)
BP301	L ^{+0.8/-0.3}	10 × (P + 1) + 8
	A ^{+0.5}	10 × (P + 1)
	B	10 × (P - 1)

Terminal Centers 9.5 mm	BP301M-□	
-------------------------	----------	---

Dimensions

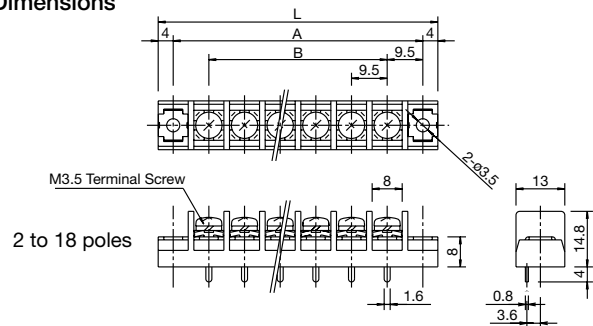

PC Board Drilling Layout (P: No. of Poles)

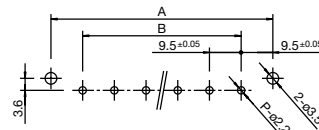

Applicable Crimping Terminal

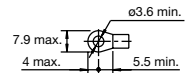

Terminal Centers 11 mm	BP301L-□	
------------------------	----------	---

Dimensions

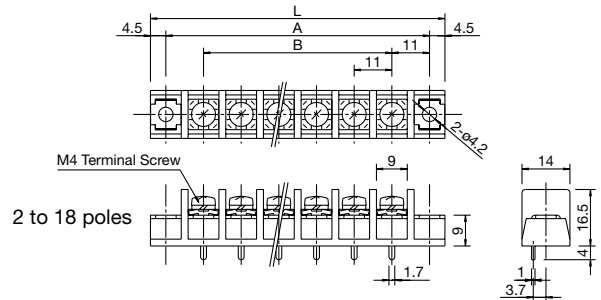

PC Board Drilling Layout (P: No. of Poles)

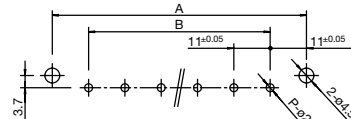

Applicable Crimping Terminal

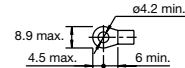

Dimension Formula

Part No.	Dimension	Formula (P: No. of Poles)
BP301M	L ^{+0.8/-0.3}	9.5 × (P + 1) + 8
	A ^{+0.5}	9.5 × (P + 1)
	B	9.5 × (P - 1)
BP301L	L ^{+0.8/-0.3}	11 × (P + 1) + 9
	A ^{+0.5}	11 × (P + 1)
	B	11 × (P - 1)

PC Board Terminal Blocks

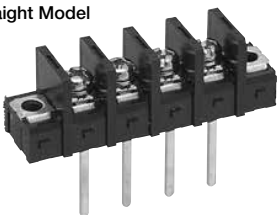
BP3 Straight Model 	Terminal Centers 7.62 mm	BP311S	Specifications <table border="1"> <tr> <td>Terminal Centers</td> <td>S = 7.62 mm</td> <td>M = 9.5 mm</td> <td>10 mm</td> <td>L = 11 mm</td> </tr> <tr> <td>Insulation Voltage</td> <td colspan="4">250V</td> </tr> <tr> <td>Rated Current</td> <td>10A</td> <td>15A</td> <td colspan="2">20A</td> </tr> <tr> <td>Terminal Screw</td> <td>M3</td> <td>M3.5</td> <td colspan="2">M4</td> </tr> <tr> <td>Tightening Torque</td> <td>0.6 to 1.0 N·m</td> <td>1.0 to 1.3 N·m</td> <td colspan="2">1.4 to 2.0 N·m</td> </tr> <tr> <td>No. of Poles (P)</td> <td>2 to 18</td> <td>2 to 18</td> <td>2 to 18</td> <td>2 to 18</td> </tr> <tr> <td>Terminal Cover Type</td> <td colspan="4">B</td> </tr> </table> Note: For details of terminal cover types, see Applicable Terminal Covers (page 3).	Terminal Centers	S = 7.62 mm	M = 9.5 mm	10 mm	L = 11 mm	Insulation Voltage	250V				Rated Current	10A	15A	20A		Terminal Screw	M3	M3.5	M4		Tightening Torque	0.6 to 1.0 N·m	1.0 to 1.3 N·m	1.4 to 2.0 N·m		No. of Poles (P)	2 to 18	2 to 18	2 to 18	2 to 18	Terminal Cover Type	B			
	Terminal Centers	S = 7.62 mm		M = 9.5 mm	10 mm	L = 11 mm																																
	Insulation Voltage	250V																																				
	Rated Current	10A		15A	20A																																	
Terminal Screw	M3	M3.5	M4																																			
Tightening Torque	0.6 to 1.0 N·m	1.0 to 1.3 N·m	1.4 to 2.0 N·m																																			
No. of Poles (P)	2 to 18	2 to 18	2 to 18	2 to 18																																		
Terminal Cover Type	B																																					
Terminal Centers 9.5 mm	BP311M																																					
Terminal Centers 10 mm	BP311																																					
Terminal Centers 11 mm	BP311L																																					

Terminal Centers 7.62 mm	BP311S-□	M3
--------------------------	----------	----

Dimensions

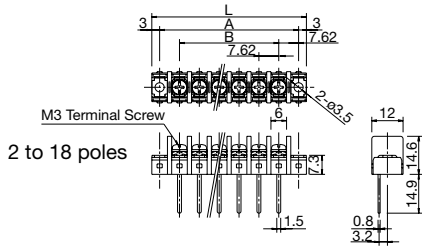

PC Board Drilling Layout (P: No. of Poles)

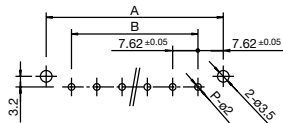

Applicable Crimping Terminal

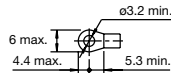

Terminal Centers 10 mm	BP311-□	M3.5
------------------------	---------	------

Dimensions

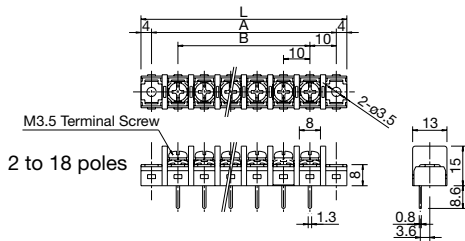

PC Board Drilling Layout (P: No. of Poles)

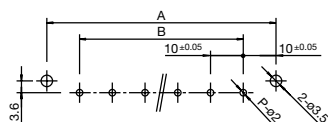

Applicable Crimping Terminal

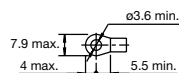

Dimension Formula

Part No.	Dimension	Formula (P: No. of Poles)
BP311S	L ^{+0.8} _{-0.3}	7.62 × (P + 1) + 6
	A ^{+0.5}	7.62 × (P + 1)
	B	7.62 × (P - 1)
BP311	L ^{+0.8} _{-0.3}	10 × (P + 1) + 8
	A ^{+0.5}	10 × (P + 1)
	B	10 × (P - 1)

Terminal Centers 9.5 mm	BP311M-□	M3.5
-------------------------	----------	------

Dimensions

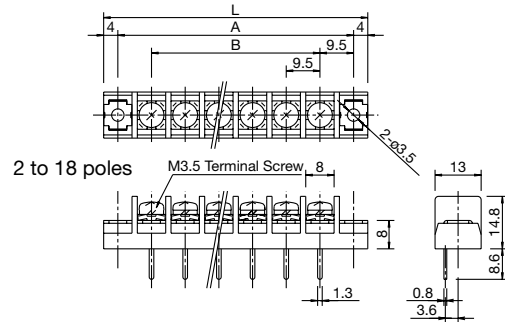

PC Board Drilling Layout (P: No. of Poles)

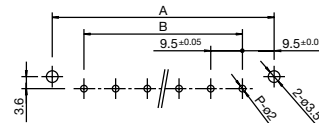

Applicable Crimping Terminal

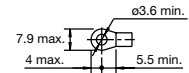

Terminal Centers 11 mm	BP311L-□	M4
------------------------	----------	----

Dimensions

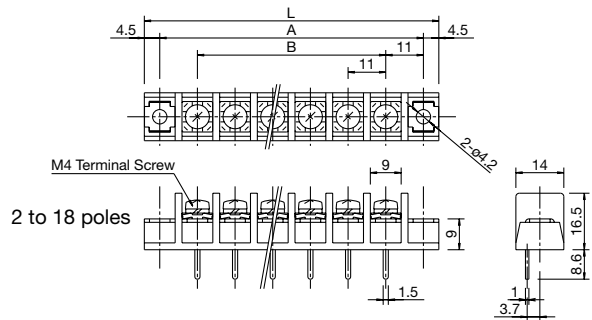

PC Board Drilling Layout (P: No. of Poles)

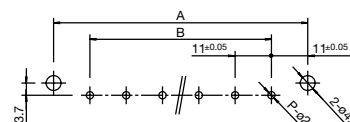

Applicable Crimping Terminal

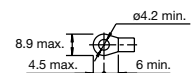

Dimension Formula

Part No.	Dimension	Formula (P: No. of Poles)
BP311M	L ^{+0.8} _{-0.3}	9.5 × (P + 1) + 8
	A ^{+0.5}	9.5 × (P + 1)
	B	9.5 × (P - 1)
BP311L	L ^{+0.8} _{-0.3}	11 × (P + 1) + 9
	A ^{+0.5}	11 × (P + 1)
	B	11 × (P - 1)

PC Board Terminal Blocks

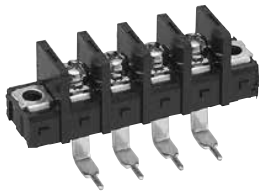
BP3 Right-angle Model 	Terminal Centers 7.62 mm	BP321S	Specifications <table border="1"> <tr> <td>Terminal Centers</td> <td>S = 7.62 mm</td> <td>M = 9.5 mm</td> <td>10 mm</td> <td>L = 11 mm</td> </tr> <tr> <td>Insulation Voltage</td> <td colspan="4">250V</td> </tr> <tr> <td>Rated Current</td> <td>10A</td> <td>15A</td> <td colspan="2">20A</td> </tr> <tr> <td>Terminal Screw</td> <td>M3</td> <td>M3.5</td> <td colspan="2">M4</td> </tr> <tr> <td>Tightening Torque</td> <td>0.6 to 1.0 N·m</td> <td colspan="2">1.0 to 1.3 N·m</td> <td>1.4 to 2.0 N·m</td> </tr> <tr> <td>No. of Poles (P)</td> <td>2 to 18</td> <td>2 to 18</td> <td>2 to 18</td> <td>2 to 18</td> </tr> <tr> <td>Terminal Cover Type</td> <td colspan="4">B</td> </tr> </table> Note: For details of terminal cover types, see Applicable Terminal Covers (page 3).	Terminal Centers	S = 7.62 mm	M = 9.5 mm	10 mm	L = 11 mm	Insulation Voltage	250V				Rated Current	10A	15A	20A		Terminal Screw	M3	M3.5	M4		Tightening Torque	0.6 to 1.0 N·m	1.0 to 1.3 N·m		1.4 to 2.0 N·m	No. of Poles (P)	2 to 18	2 to 18	2 to 18	2 to 18	Terminal Cover Type	B			
	Terminal Centers	S = 7.62 mm		M = 9.5 mm	10 mm	L = 11 mm																																
	Insulation Voltage	250V																																				
	Rated Current	10A		15A	20A																																	
Terminal Screw	M3	M3.5	M4																																			
Tightening Torque	0.6 to 1.0 N·m	1.0 to 1.3 N·m		1.4 to 2.0 N·m																																		
No. of Poles (P)	2 to 18	2 to 18	2 to 18	2 to 18																																		
Terminal Cover Type	B																																					
Terminal Centers 9.5 mm	BP321M																																					
Terminal Centers 10 mm	BP321																																					
Terminal Centers 11 mm	BP321L																																					

Terminal Centers 7.62 mm	BP321S-□	M3
--------------------------	----------	----

Dimensions

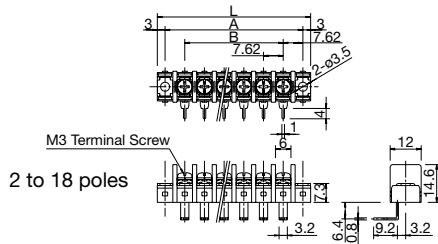

PC Board Drilling Layout (P: No. of Poles)

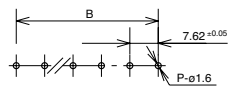

Applicable Crimping Terminal

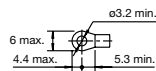

Applicable Right-angle clip:
Part No. BPF-L1

Terminal Centers 10 mm	BP321-□	M3.5
------------------------	---------	------

Dimensions

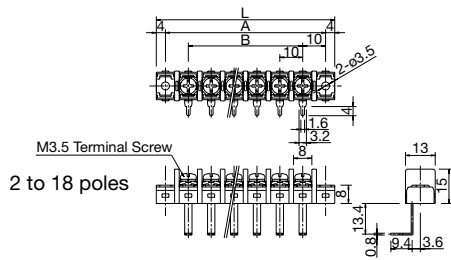

PC Board Drilling Layout (P: No. of Poles)

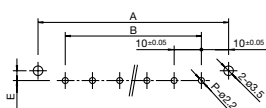

Applicable Crimping Terminal

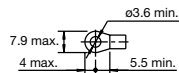

Applicable Right-angle clip:
Part No. BPF-L1

Dimension Formula

Part No.	Dimension	Formula (P: No. of Poles)
BP321S	L $\begin{smallmatrix} +0.8 \\ -0.3 \end{smallmatrix}$	$7.62 \times (P + 1) + 6$
	A ± 0.5	$7.62 \times (P + 1)$
	B	$7.62 \times (P - 1)$
BP321	L $\begin{smallmatrix} +0.8 \\ -0.3 \end{smallmatrix}$	$10 \times (P + 1) + 8$
	A ± 0.5	$10 \times (P + 1)$
	B	$10 \times (P - 1)$

Terminal Centers 9.5 mm	BP321M-□	M3.5
-------------------------	----------	------

Dimensions

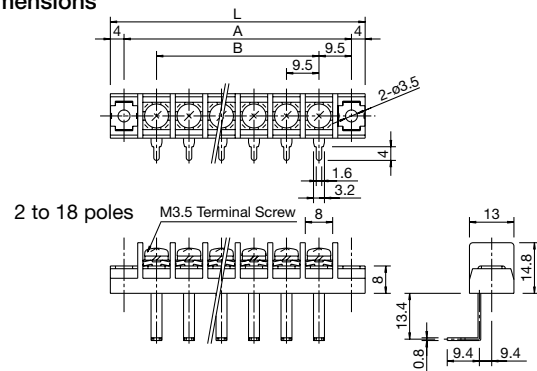

PC Board Drilling Layout (P: No. of Poles)

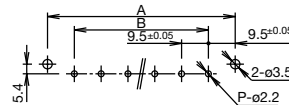

Applicable Crimping Terminal

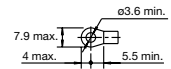

Applicable Right-angle clip:
Part No. BPF-L1

Terminal Centers 11 mm	BP321L-□	M4
------------------------	----------	----

Dimensions

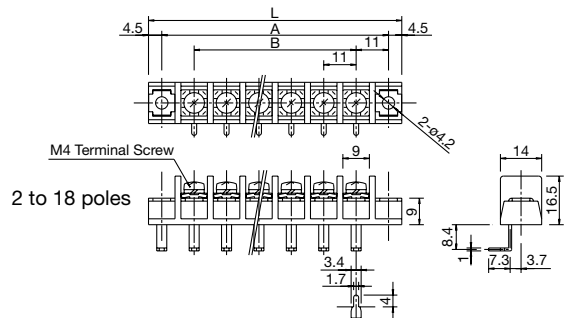

PC Board Drilling Layout (P: No. of Poles)

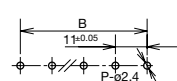

Applicable Crimping Terminal

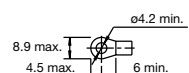

Applicable Right-angle clip:
Part No. BPF-L7

Dimension Formula

Part No.	Dimension	Formula (P: No. of Poles)
BP321M	L $\begin{smallmatrix} +0.8 \\ -0.3 \end{smallmatrix}$	$9.5 \times (P + 1) + 8$
	A ± 0.5	$9.5 \times (P + 1)$
	B	$9.5 \times (P - 1)$
BP321L	L $\begin{smallmatrix} +0.8 \\ -0.3 \end{smallmatrix}$	$11 \times (P + 1) + 9$
	A ± 0.5	$11 \times (P + 1)$
	B	$11 \times (P - 1)$

PC Board Terminal Blocks

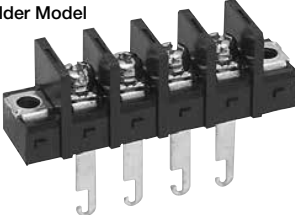
BP3 Solder Model 	Terminal Centers 7.62 mm	BP341S	Specifications <table border="1"> <tr> <td>Terminal Centers</td> <td>S = 7.62 mm</td> <td>M = 9.5 mm</td> <td>10 mm</td> <td>L = 11 mm</td> </tr> <tr> <td>Insulation Voltage</td> <td colspan="4">250V</td> </tr> <tr> <td>Rated Current</td> <td>10A</td> <td>15A</td> <td colspan="2">20A</td> </tr> <tr> <td>Terminal Screw</td> <td>M3</td> <td>M3.5</td> <td colspan="2">M4</td> </tr> <tr> <td>Tightening Torque</td> <td>0.6 to 1.0 N·m</td> <td colspan="2">1.0 to 1.3 N·m</td> <td>1.4 to 2.0 N·m</td> </tr> <tr> <td>No. of Poles (P)</td> <td>2 to 18</td> <td>2 to 18</td> <td>2 to 18</td> <td>2 to 18</td> </tr> <tr> <td>Terminal Cover Type</td> <td colspan="4">B</td> </tr> </table> <p>Note: For details of terminal cover types, see Applicable Terminal Covers (page 3).</p>	Terminal Centers	S = 7.62 mm	M = 9.5 mm	10 mm	L = 11 mm	Insulation Voltage	250V				Rated Current	10A	15A	20A		Terminal Screw	M3	M3.5	M4		Tightening Torque	0.6 to 1.0 N·m	1.0 to 1.3 N·m		1.4 to 2.0 N·m	No. of Poles (P)	2 to 18	2 to 18	2 to 18	2 to 18	Terminal Cover Type	B			
	Terminal Centers	S = 7.62 mm		M = 9.5 mm	10 mm	L = 11 mm																																
	Insulation Voltage	250V																																				
	Rated Current	10A		15A	20A																																	
Terminal Screw	M3	M3.5	M4																																			
Tightening Torque	0.6 to 1.0 N·m	1.0 to 1.3 N·m		1.4 to 2.0 N·m																																		
No. of Poles (P)	2 to 18	2 to 18	2 to 18	2 to 18																																		
Terminal Cover Type	B																																					
Terminal Centers 9.5 mm	BP341M																																					
Terminal Centers 10 mm	BP341																																					
Terminal Centers 11 mm	BP341L																																					

Terminal Centers 7.62 mm	BP341S-□	M3
--------------------------	----------	----

Dimensions

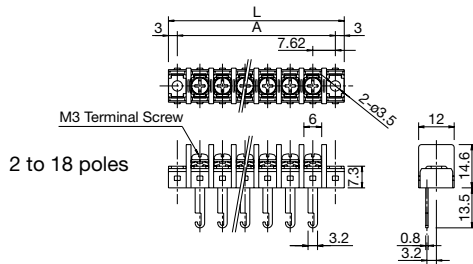

Applicable Crimping Terminal

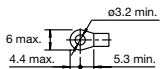

Terminal Centers 10 mm	BP341-□	M3.5
------------------------	---------	------

Dimensions

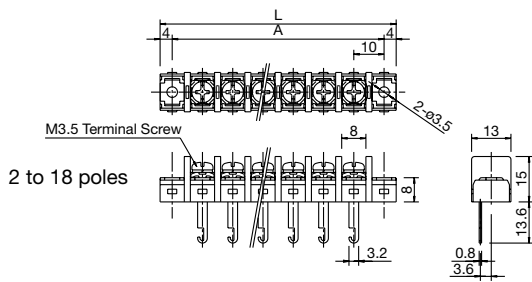

Applicable Crimping Terminal

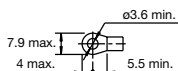

Dimension Formula

Part No.	Dimension	Formula (P: No. of Poles)
BP341S	$L \begin{smallmatrix} +0.8 \\ -0.3 \end{smallmatrix}$	$7.62 \times (P + 1) + 6$
	$A \pm 0.5$	$7.62 \times (P + 1)$
BP341	$L \begin{smallmatrix} +0.8 \\ -0.3 \end{smallmatrix}$	$10 \times (P + 1) + 8$
	A	$10 \times (P + 1)$

±0.5

Terminal Centers 9.5 mm	BP341M-□	M3.5
-------------------------	----------	------

Dimensions

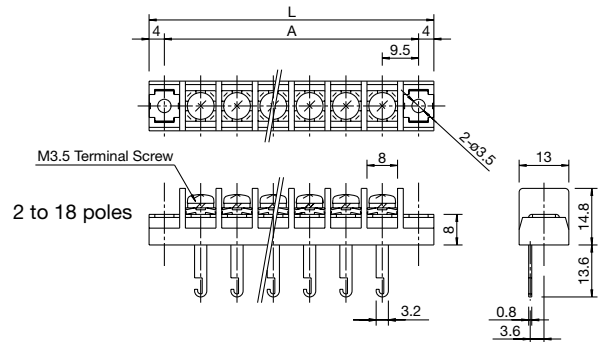

Applicable Crimping Terminal

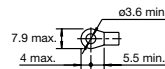

Terminal Centers 11 mm	BP341L-□	M4
------------------------	----------	----

Dimensions

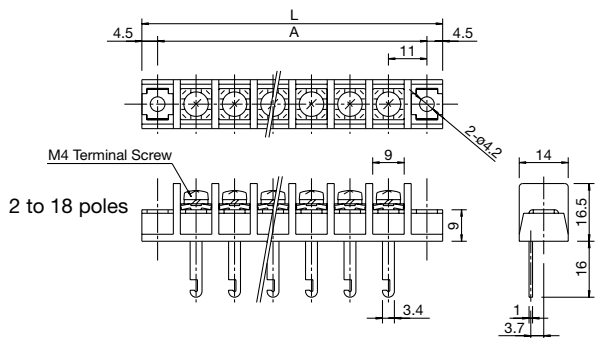

Applicable Crimping Terminal

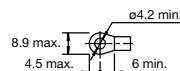



Dimension Formula

Part No.	Dimension	Formula (P: No. of Poles)
BP341M	$L \begin{smallmatrix} +0.8 \\ -0.3 \end{smallmatrix}$	$9.5 \times (P + 1) + 8$
	$A \pm 0.5$	$9.5 \times (P + 1)$
BP341L	$L \begin{smallmatrix} +0.8 \\ -0.3 \end{smallmatrix}$	$11 \times (P + 1) + 9$
	A	$11 \times (P + 1)$

±0.5

PC Board Terminal Blocks

BP3 Center Pin Model 	Terminal Centers 7.62 mm	BP305S	Specifications <table border="1"> <tr> <td>Terminal Centers</td> <td>S = 7.62 mm</td> <td>10 mm</td> </tr> <tr> <td>Insulation Voltage</td> <td colspan="2">250 V</td> </tr> <tr> <td>Rated Current</td> <td>10A</td> <td>15A</td> </tr> <tr> <td>Terminal Screw</td> <td>M3</td> <td>M3.5</td> </tr> <tr> <td>Tightening Torque</td> <td>0.6 to 1.0 N·m</td> <td>1.0 to 1.3 N·m</td> </tr> <tr> <td>No. of Poles (P)</td> <td>2 to 18</td> <td>2 to 18</td> </tr> <tr> <td>Terminal Cover Type</td> <td colspan="2">B</td> </tr> </table> Note: For details of terminal cover types, see Applicable Terminal Covers (page 3).	Terminal Centers	S = 7.62 mm	10 mm	Insulation Voltage	250 V		Rated Current	10A	15A	Terminal Screw	M3	M3.5	Tightening Torque	0.6 to 1.0 N·m	1.0 to 1.3 N·m	No. of Poles (P)	2 to 18	2 to 18	Terminal Cover Type	B	
	Terminal Centers	S = 7.62 mm		10 mm																				
Insulation Voltage	250 V																							
Rated Current	10A	15A																						
Terminal Screw	M3	M3.5																						
Tightening Torque	0.6 to 1.0 N·m	1.0 to 1.3 N·m																						
No. of Poles (P)	2 to 18	2 to 18																						
Terminal Cover Type	B																							
Terminal Centers 10 mm	BP305																							

Terminal Centers 7.62 mm	BP305S-□	
--------------------------	----------	---

Terminal Centers 10 mm	BP305-□	
------------------------	---------	---

Dimensions

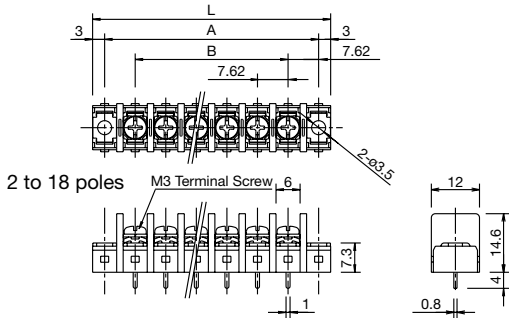

Dimensions

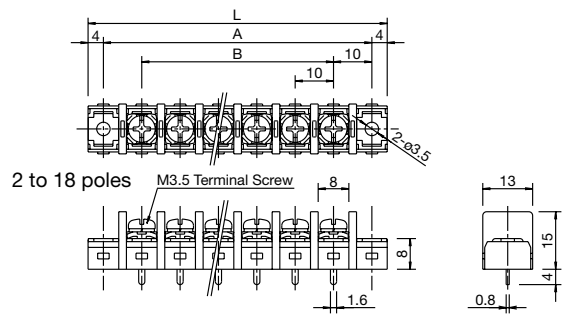

PC Board Drilling Layout (P: No. of Poles)

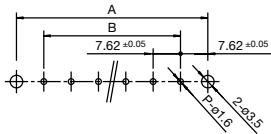

Applicable Crimping Terminal

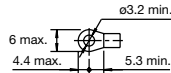

PC Board Drilling Layout (P: No. of Poles)

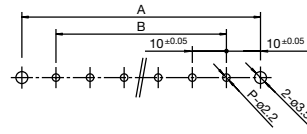

Applicable Crimping Terminal

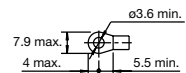

Dimension Formula

Part No.	Dimension	Formula (P: No. of Poles)
BP305S	L $\begin{smallmatrix} +0.8 \\ -0.3 \end{smallmatrix}$	$7.62 \times (P + 1) + 6$
	A ± 0.5	$7.62 \times (P + 1)$
	B	$7.62 \times (P - 1)$

Dimension Formula

Part No.	Dimension	Formula (P: No. of Poles)
BP305	L $\begin{smallmatrix} +0.8 \\ -0.3 \end{smallmatrix}$	$10 \times (P + 1) + 8$
	A ± 0.5	$10 \times (P + 1)$
	B	$10 \times (P - 1)$

PC Board Terminal Blocks

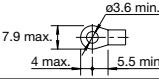
	Part No.	BP101V	Space-saving terminal block with rear barrier to ensure proper insulation distance <ul style="list-style-type: none"> • Barrier on the back of the body ensures insulation distance. • Space saving. • Optional cover fastens to the body without using mounting lug.
	Terminal Centers	10 mm	
	Insulation Voltage	250V	
	Rated Current	15A	
	Terminal Screw	M3.5	
	Tightening Torque	2 to 15	
Applicable Crimping Terminal			

Terminal Centers 10 mm	BP101V-□	
-------------------------------	-----------------	---

Dimensions

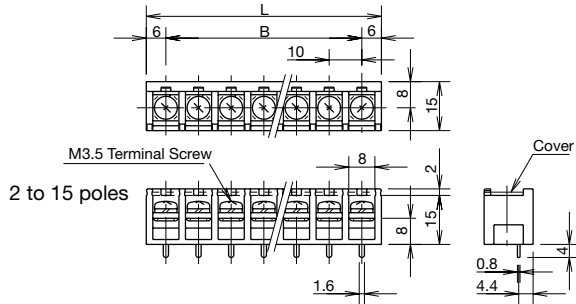

PC Board Drilling Layout (P: No. of Poles)

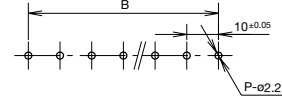



Dimension List (mm)



No. of Poles	2	3	4	5	6	7	8	9	10	11	12	13	14	15
L ±0.5	22	32	42	52	62	72	82	92	102	112	122	132	142	152
B ±0.5	10	20	30	40	50	60	70	80	90	100	110	120	130	140

Note: The optional cover is made to fit a 15-pole structure; cut the cover to fit the No. of Poles needed.

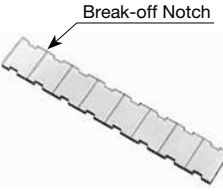
Accessories



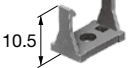
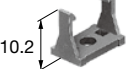

	Name	Part No.	Specification	Applicable Terminal Block	Remarks
Type A	Hinged Terminal Cover 	BPA-CA□S	Terminal Centers 7.62 mm	All BP1 series (terminal centers 7.62 mm), 2 to 20-pole only All BP2 series (terminal centers 7.62 mm), 2 to 18-pole only (Note 1)	Use cover supports to hold the cover. The cover is hinged, for easy checking of terminal numbers regardless of whether the cover is open or not. A marking strip is supplied. Specify the number of poles in place of □ in the Part No. (Note 2)
	Material: Polycarbonate (transparent), UL94-V2	BPA-CA□	Terminal Centers 10 mm	All BP1 series (terminal centers 10 mm), 2 to 20-pole only All BP2 series (terminal centers 10 mm), 2 to 18-pole only (Note 1)	
	Cover Support 	BPA-EA1	—	All BP1 series (terminal centers 7.62 mm or 10 mm), 2 to 20-pole All BP2 series (terminal centers 7.62 mm or 10 mm), 2 to 18-pole	A cover support is needed on each end of the terminal block to fasten the cover (two pieces in total). Be sure to order the cover supports when using the hinged terminal cover.
	Material: Polyacetal (black)				
Type B	Marking Strip 	BPA-MA1S (12 poles) BPA-MA2S (20 poles)	Terminal Centers 7.62 mm	All BP1 series (terminal centers 7.62 mm), 2 to 20-pole only All BP2 series (terminal centers 7.62 mm), 2 to 18 pole only	A marking strip comes standard with a terminal cover; extra marking strips can be ordered as required. The marking strip can be cut so as to cover the entire terminal block as required.
		BPA-MA1 (12 poles) BPA-MA2 (20 poles)	Terminal Centers 10 mm	All BP1 series (terminal centers 10 mm), 2 to 20-pole only All BP2 series (terminal centers 10 mm), 2 to 18-pole only	
	Removable Terminal Cover 	BPA-C1S	Length: 244 Width: 12 Thickness: 1	BP201S, BP211S, BP221S, BP241S, and BP251S, 19 to 21-pole and 25-pole only All BP3 series (terminal centers 7.62 mm) (Note 1)	This cover is 32-poles long and can be cut as required. Cover length calculation (P: No. of poles) (P + 2) × 7.62 mm
		BPA-C1	Length: 270 Width: 13 Thickness: 1	BP201, BP211, BP212, BP221, BP225, BP226, BP241, and BP251, 19 to 21-pole only All BP3 series (terminal centers 10 mm) (Note 1)	This cover is 27-poles long and can be cut as required. Cover length calculation (P: No. of poles) (P + 2) × 10 mm
		BPA-C1M	Length: 256 Width: 13 Thickness: 1	All BP2 and BP3 series (terminal centers 9.5 mm) (Note 1)	This cover is 27-poles long and can be cut as required. Cover length calculation (P: No. of poles) (P + 2) × 9.5 mm
	Material: Polycarbonate (transparent), UL94-V2	BPA-C1L	Length: 264 Width: 14 Thickness: 1	All BP2 and BP3 series (terminal centers 11 mm) (Note 1)	This cover is 24-poles long and can be cut as required. Cover length calculation (P: No. of poles) (P + 2) × 11 mm

PC Board Terminal Blocks

Name	Part No.	Specification	Applicable Terminal Block	Remarks
Cover Holder  Material: Polyacetal (black)	BPA-E1S	—	All BP3 series (terminal centers 7.62 mm)	Used to hold removable terminal covers; use on both ends of the terminal block.
Cover Holder  Material: Polyacetal (black)	BPA-E1	—	All BP3 series (terminal centers 10 mm)	
Cover Holder  Material: Polyacetal (black)	BPA-E1M	—	All BP2 and BP3 series (terminal centers 9.5 mm)	
Cover Holder  Material: Polyacetal (black)	BPA-E1L	—	All BP2 and BP3 series (terminal centers 11 mm)	

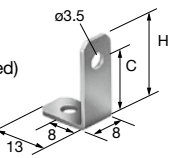
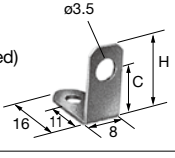
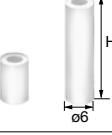
Note 1: For details of terminal cover types, see Applicable Terminal Covers (page 3).

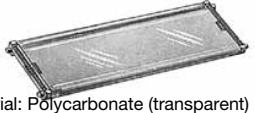
Note 2: When specifying the Number of Poles for a BP2 terminal block, add two to the Number of Poles in the Part No. of the BP2 terminal block.

Name	Part No.	Specification	Applicable Terminal Block	Remarks
Right-angle Clip  Material: Steel (black nickel-plated) Thickness: 1t	BPF-L1	H = 14 C = 9	BP221, BP221M, BP321, BP321M	Used to mount right-angle model terminal blocks to a printed circuit board.
Right-angle Clip  Material: Steel (black nickel-plated) Thickness: 1t	BPF-L7	H = 12 C = 7	BP221L, BP321L	
Spacer  Material: Polyacetal (white) (Inside diameter: $\phi 3.2$)	BPA-S1	H = 4	BP111M, BP111, BP111L, BP211, BP211M, BP211L, BP311, BP311M, BP311L	Used to suspend straight model terminal blocks over a printed circuit board.
	BPA-S4	H = 10	BP111S, BP211S, BP311S	
Cover  Material: Polycarbonate (transparent)	BPA-C2	Length: 250 Width: 15 Thickness: 1t	BP101V	This cover is 25-poles long and can be cut as required.
Cover (for double-deck terminal blocks)  Material: Polycarbonate (transparent)	BL9Z-C □ B	Terminal Centers 7.62 mm	BL2B-T □ 1C, BL2B-S □ 1C	The cover comes standard with the double-deck terminal block. Order extra covers as required. Specify the number of poles in place of □ in the Part No. □: 10, 16, 20, 30, 34
	BL9Z-C □ C	Terminal Centers 8.5 mm	BL2C-T □ 1C, BL2C-S □ 1C	
	BL9Z-C □ E	Terminal Centers 10 mm	BL2E-S □ 1C	
Marking Strip 	BL9Z-M □ B	Terminal Centers 7.62 mm	BL2B-T □ 1C, BL2B-S □ 1C	
	BL9Z-M □ C	Terminal Centers 8.5 mm	BL2C-T □ 1C, BL2C-S □ 1C	
	BL9Z-M □ E	Terminal Centers 10 mm	BL2E-S □ 1C	

PC Board Terminal Blocks

Jumpers for 6 poles (Material: Nickel-plated Brass) Note: Jumpers for more than 6 poles are not available.

Terminal Centers	Shape	Insulation Sheath	Part No.	Dimensions (mm)	Rated Current	Applicable Terminal Block	Remarks
7.62 mm	Ring	Without	BPJ-26		10A	All BP1 to BP3 (terminal centers 7.62 mm) BL2B-T □ 1C BL2B-S □ 1C	
		With	BPJ-26B				
	Spade	Without	BPJ-26F				
		With	BPJ-26FB				
9.5 mm	Ring	Without	BPJ-36		15A	All BP1 to BP3 (terminal centers 9.5 mm)	
		With	BPJ-36B				
	Spade	Without	BPJ-36F				
		With	BPJ-36FB				
10 mm	Ring	Without	BPJ-46		15A	All BP1 to BP3 (terminal centers 10 mm) BL2E-S □ 1C, BP101V	Ring Spade Used for jumper wiring. These jumpers are for 6-pole terminal blocks and can be cut as required.
		With	BPJ-46B				
	Spade	Without	BPJ-46F				
		With	BPJ-46FB				
11 mm	Ring	Without	BPJ-56		20A	All BP1 to BP3 (terminal centers 11 mm)	
		With	BPJ-56B				
	Spade	Without	BPJ-56F				
		With	BPJ-56FB				
8.5 mm	Ring	Without	BNJ36		15A	BL2C-T □ 1C, BL2C-S □ 1C	
		With	BNJ36B				
	Spade	Without	BNJ36F				
		With	BNJ36FB				

Note 1: The color of the insulation sheath is black.

Note 2: Ensure that the total current to the jumper does not exceed the rated current.

PC Board Terminal Blocks

Dimensions with a Type A Cover (Hinged Terminal Cover) Attached

Terminal Centers 7.62 mm/Basic Model Terminal (BP101S-□)

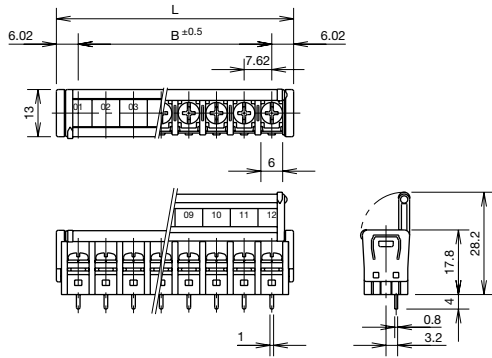

Terminal Centers 10 mm/Basic Model Terminal (BP101-□)

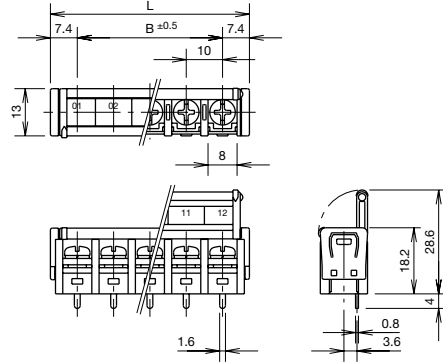

(BP201S-□)

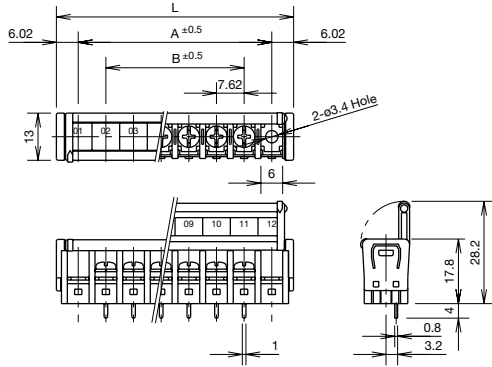

(BP201-□)

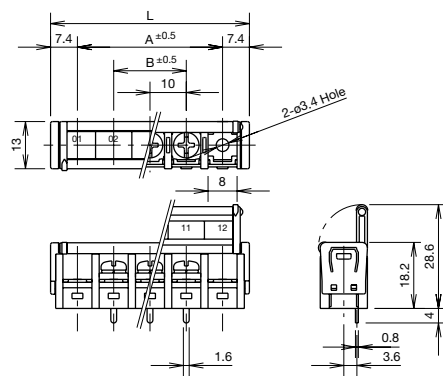

Dimension List (mm)

Part No.	No. of Poles (P)	2	3	4	5	6	7	8	9	10	Formula
BP101S	L	19.66	27.28	34.9	42.52	50.14	57.76	65.38	73	80.62	$7.62 \times (P - 1) + 12.04$
	B	7.62	15.24	22.86	30.48	38.1	45.72	53.34	60.96	68.58	$7.62 \times (P - 1)$
BP101	L	24.8	34.8	44.8	54.8	64.8	74.8	84.8	94.8	104.8	$10 \times (P - 1) + 14.8$
	B	10	20	30	40	50	60	70	80	90	$10 \times (P - 1)$
BP201S	L	34.9	42.52	50.14	57.76	65.38	73	80.62	88.24	95.86	$7.62 \times (P + 1) + 12.04$
	A	22.86	30.48	38.1	45.72	53.34	60.96	68.58	76.2	83.82	$7.62 \times (P + 1)$
	B	7.62	15.24	22.86	30.48	38.1	45.72	53.34	60.96	68.58	$7.62 \times (P - 1)$
BP201	L	44.8	54.8	64.8	74.8	84.8	94.8	104.8	114.8	124.8	$10 \times (P + 1) + 14.8$
	A	30	40	50	60	70	80	90	100	110	$10 \times (P + 1)$
	B	10	20	30	40	50	60	70	80	90	$10 \times (P - 1)$

Note 1: Dimensions of models other than above basic model terminals are identical except for dimensions of the terminal fittings.

Note 2: See page 3 for the terminal blocks on which Type A cover can be attached.

Mounting Method (BP1 and BP2)

BP1

BP101S* BP101M BP101* BP101L	BP111S* BP111M BP111* BP111L
<p>PC Board</p>	<p>Spacer (BPA-S1 BPA-S2 BPA-S4)</p>

* Type A cover can be attached. See page 3 for details.

BP2 (when Type B cover is used)

BP201S* 	BP211S* 	BP221S* 	BP241S*
BP201M 	BP211M 	BP221M 	BP241M
BP201* 	BP211* 	BP221* 	BP241*
BP201L 	BP211L 	BP221L 	BP241L

Note 1: When a terminal cover is not used, cover holders are not required.

Note 2: When the mounting holes are tapped, nuts are not required.

Note 3: Type A cover can be used. See page 3 for details. For mounting, see page 25.

PC Board Terminal Blocks

Mounting Method (BP3)

BP3 (When Type B cover is used)

<p>BP301S</p> <p>Cover Holder (BPA-E1S) Cover (BPA-C1S) M3 Screw PC Board Nut</p>	<p>BP311S</p> <p>Cover Holder (BPA-E1S) Cover (BPA-C1S) M3 Screw Spacer (BPA-S4) PC Board</p>	<p>BP321S</p> <p>Cover Holder (BPA-E1S) Cover (BPA-C1S) M3 Screw PC Board</p>	<p>BP341S</p> <p>Cover Holder (BPA-E1S) Cover (BPA-C1S) M3 Screw PC Board</p>
<p>BP301M</p> <p>Cover Holder (BPA-E1M) Cover (BPA-C1M) M3 Screw PC Board Nut</p>	<p>BP311M</p> <p>Cover Holder (BPA-E1M) Cover (BPA-C1M) M3 Screw Spacer (BPA-S1) BPA-S2 PC Board</p>	<p>BP321M</p> <p>Cover Holder (BPA-E1M) Cover (BPA-C1M) M3 Screw PC Board Right-angle Clip (BPF-L1) BPF-L2</p>	<p>BP341M</p> <p>Cover Holder (BPA-E1M) Cover (BPA-C1M) M3 Screw PC Board</p>
<p>BP301</p> <p>Cover Holder (BPA-E1) Cover (BPA-C1) M3 Screw PC Board Nut</p>	<p>BP311</p> <p>Cover Holder (BPA-E1) Cover (BPA-C1) M3 Screw Spacer (BPA-S1) BPA-S2 PC Board</p>	<p>BP321</p> <p>Cover Holder (BPA-E1) Cover (BPA-C1) M3 Screw PC Board Right-angle Clip (BPF-L1) BPF-L2</p>	<p>BP341</p> <p>Cover Holder (BPA-E1) Cover (BPA-C1) M3 Screw PC Board</p>
<p>BP301L</p> <p>Cover Holder (BPA-E1L) Cover (BPA-C1L) M3 or M4 Screw PC Board Nut</p>	<p>BP311L</p> <p>Cover Holder (BPA-E1L) Cover (BPA-C1L) M3 or M4 Screw Spacer (BPA-S1) PC Board</p>	<p>BP321L</p> <p>Cover Holder (BPA-E1L) Cover (BPA-C1L) M3 or M4 Screw PC Board Right-angle Clip (BPF-L7)</p>	<p>BP341L</p> <p>Cover Holder (BPA-E1L) Cover (BPA-C1L) M3 or M4 Screw PC Board</p>

Note 1: When a terminal cover is not used, cover holders are not required.

Note 2: When the mounting holes are tapped, nuts are not required.

Note 3: Type A covers cannot be used.

Safety Precautions

- Turn off power before installation, removal, wiring, maintenance, and inspection. Failure to turn off may cause electrical shocks or fire hazard.
- Be sure to use the terminal blocks within rated specifications, otherwise electrical shock and fire hazard may occur.
- For wiring, use wires of proper size to meet voltage and current requirements. Tighten the terminal screws to adequate tightening torque. Failure to tighten the terminal screws or imperfect soldering may cause overheating and fire.

Instructions

Notes on Wiring

For wiring to screw terminals, use wires of proper size to meet voltage and current requirements. Tighten the terminal screws to adequate tightening torque shown in the table below.

Terminal Block	Terminal Screw	Terminal Screws Torque Tightening
BP***S (terminal centers 7.62 mm) BL2B	M3	0.6 to 1.0 N·m (6.1 to 10.2 kgf·cm)
BP*** (terminal centers 10 mm) BP***M (terminal centers 9.5 mm) BP101V BL2C	M3.5	1.0 to 1.3 N·m (10.2 to 13.3 kgf·cm)
BP***L (terminal centers 11 mm) BL2E	M4	1.4 to 2.0 N·m (14.3 to 20.4 kgf·cm)

Notes on Soldering

(For flow soldering)

Complete soldering to terminal fittings within five seconds at 260°C.

(For manual soldering)

Complete soldering to terminal fittings within five seconds at 360°C using a 60W soldering iron.

Mounting a Hinged Terminal Cover (Type A)

Mounting Method

- (1) With a cover support placed on the upper surface of the side of the terminal block, strongly press the lower side of the cover support to the terminal block, and the cover support will be fastened with a click.
- (2) Insert a marking strip into the hinged terminal cover.
- (3) With the raised portion of the hinged terminal cover inserted into the recess in a cover support, gently bend the cover to enter into the other recess of the cover support .
(Be careful not to bend the cover forcibly, or the cover may break.)

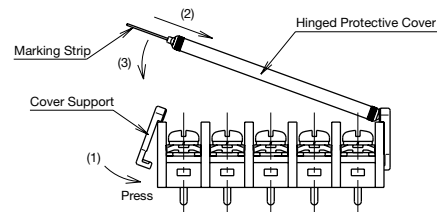

PC Board Terminal Blocks

BL Series PC Board Terminal Blocks: RoHS Directive-Compliant

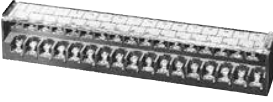
	Model	BL2B	BL2C	BL2E	Part No. Development BL2-□-□ 1C Terminal Centers (mm) B: 7.62 mm C: 8.5 mm E: 10 mm No. of Poles 10, 16, 20, 30, 34 Terminal structure T: TDT touch down terminal (7.62 mm and 8.5 mm terminal centers only) S: Self-lifting terminal
	Terminal Centers	7.62 mm	8.5 mm	10 mm	
	Tightening Torque	250V			
	Insulation Voltage	10A	15A	20A	
	Current	M3	M3.5	M4	
	No. of Poles (P)	10, 16, 20, 30, 34			
Tightening Torque	0.6 to 1.0 N·m	1.0 to 1.3 N·m	1.4 to 2.0 N·m		

Space and Labor Saving – Double-deck structure with Touch Down Terminals

Terminal Centers 7.62 mm	BL2B-T□1C, BL2B-S□1C
--------------------------	----------------------

Dimensions

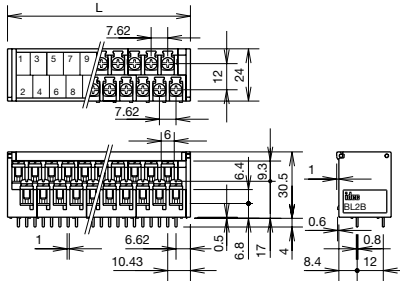

PC Board Drilling Layout

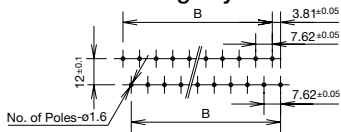

Applicable Crimping Terminal



L and B Dimensions (mm)

Poles	10	16	20	30	34
L	45.91	68.77	84.01	122.11	137.35
B	30.48	53.34	68.58	106.68	121.92

Terminal Centers 8.5 mm	BL2C-T□1C, BL2C-S□1C
-------------------------	----------------------

Dimensions

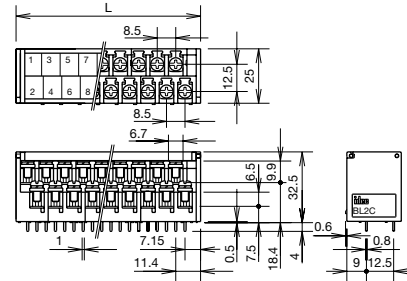

PC Board Drilling Layout

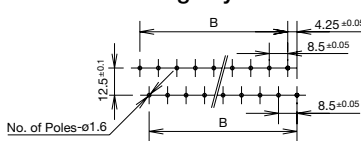

Applicable Crimping Terminal

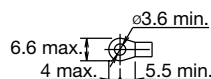

L and B Dimensions (mm)

Poles	10	16	20	30	34
L	50.75	76.25	93.25	135.75	152.75
B	34	59.5	76.5	119	136

Terminal Centers 10 mm	BL2E-S□1C
------------------------	-----------

Dimensions

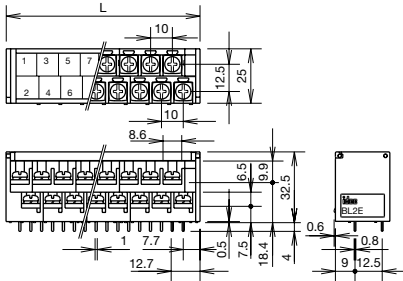

PC Board Drilling Layout

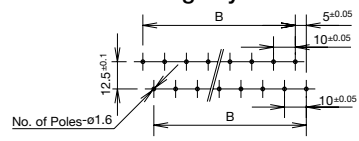

Applicable Crimping Terminal

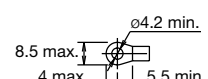

L and B Dimensions (mm)

Poles	10	16	20	30	34
L	59	89	109	159	179
B	40	70	90	140	160

Terminal Centers	No. of Poles	Ordering Part No.	
		Touch Down Terminal Block	Self-lifting Terminal Block
7.62 mm	10	BL2B-T101C	BL2B-S101C
	16	BL2B-T161C	BL2B-S161C
	20	BL2B-T201C	BL2B-S201C
	30	BL2B-T301C	BL2B-S301C
	34	BL2B-T341C	BL2B-S341C
8.5 mm	10	BL2C-T101C	BL2C-S101C
	16	BL2C-T161C	BL2C-S161C
	20	BL2C-T201C	BL2C-S201C
	30	BL2C-T301C	BL2C-S301C
	34	BL2C-T341C	BL2C-S341C
10 mm	10	-	BL2E-S101C
	16	-	BL2E-S161C
	20	-	BL2E-S201C
	30	-	BL2E-S301C
	34	-	BL2E-S341C

Specifications and other descriptions in this brochure are subject to change without notice.



IDEC CORPORATION

6-64, Nishi-Miyahara 2-Chome, Yodogawa-ku, Osaka 532-0004, Japan
Tel: +81-6-6398-2527, Fax: +81-6-6398-2547
E-mail: marketing@idec.co.jp

IDEC CORPORATION (USA)
1175 Elko Drive, Sunnyvale, CA 94089-2209, USA
Tel: +1-408-747-0550 / (800) 262-IDEC (4332)
Fax: +1-408-744-9055 / (800) 635-6246
E-mail: opencontact@idec.com

IDEC CANADA LIMITED
3155 Pepper Mill Court, Unit 4
Mississauga, Ontario, L5L 4X7, Canada
Tel: +1-905-890-8561, Toll Free: (888) 317-IDEC (4332)
Fax: +1-905-890-8562
E-mail: sales@ca.idec.com

IDEC AUSTRALIA PTY. LTD.
Unit 17, 104 Ferntree Gully Road,
Oakleigh, Victoria 3166, Australia
Tel: +61-3-8523-5900, Toll Free: 1800-68-4332
Fax: +61-3-8523-5999
E-mail: sales@au.idec.com

IDEC ELEKTROTECHNIK GmbH
Heselerstruecken 8, 22453 Hamburg, Germany
Tel: +49-40-25 30 54 - 0, Fax: +49-40-25 30 54 - 24
E-mail: service@eu.idec.com

IDEC (SHANGHAI) CORPORATION
Room 701-702 Chong Hing Finance Center,
No. 288 Nanjing Road West, Shanghai 200003, PRC
Tel: +86-21-6135-1515
Fax: +86-21-6135-6225 / +86-21-6135-6226
E-mail: idec@cn.idec.com

IDEC (BEIJING) CORPORATION
Room 211B, Tower B, The Grand Pacific Building,
8A Guanghua Road, Chaoyang District,
Beijing 100026, PRC
Tel: +86-10-6581-6131, Fax: +86-10-6581-5119

IDEC (SHENZHEN) CORPORATION
Unit AB-3B2, Tian Xiang Building, Tian'an Cyber Park,
Fu Tian District, Shenzhen, Guang Dong 518040, PRC
Tel: +86-755-8356-2977, Fax: +86-755-8356-2944

IDEC IZUMI (H.K.) CO., LTD.
Unit G & H, 26/F., MG Tower, No. 133 Hoi Bun Road,
Kwun Tong, Kowloon, Hong Kong
Tel: +852-2803-8989, Fax: +852-2565-0171
E-mail: info@hk.idec.com

IDEC TAIWAN CORPORATION
8F-1, No. 79, Hsin Tai Wu Road, Sec. 1,
Hsi-Chih District, 22101 New Taipei City, Taiwan
Tel: +886-2-2698-3929, Fax: +886-2-2698-3931
E-mail: service@tw.idec.com

IDEC IZUMI ASIA PTE. LTD.
No. 31, Tannery Lane #05-01,
HB Centre 2, Singapore 347788
Tel: +65-6746-1155, Fax: +65-6844-5995
E-mail: info@sg.idec.com

IDEC ASIA (THAILAND) CO.,LTD.
20th Fl., Sorachai Bldg., No.23/78,
Soi Sukhumvit 63, Sukhumvit Rd.,
Klongton-nua, Wattana, Bangkok 10110
Tel: +662-392-9765, Fax: +662-392-9768
E-mail: sales@th.idec.com

www.idec.com